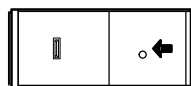
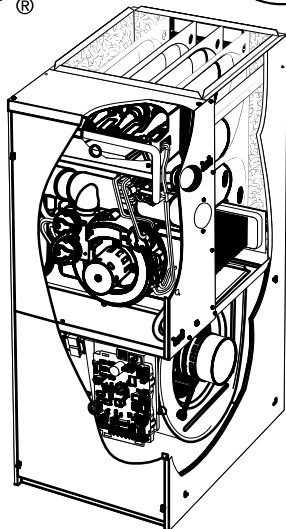
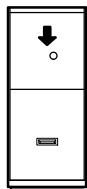




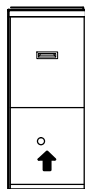
© 2011 Lennox Industries Inc.  
Dallas, Texas, USA



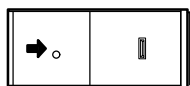
HORIZONTAL LEFT



DOWNFLOW



UPFLOW



HORIZONTAL RIGHT

## WARNING

Improper installation, adjustment, alteration, service or maintenance can cause property damage, personal injury or loss of life. Installation and service must be performed by a licensed professional installer (or equivalent), service agency or the gas supplier.

# INSTALLATION INSTRUCTIONS G71MPP

DAVE LENNOX SIGNATURE®  
COLLECTION GAS FURNACE  
MULT-POSITION VARIABLE CAPACITY

506509-01  
04/2011  
Supersedes 07/2010

TP Technical  
Publications

Litho U.S.A.

**THIS MANUAL MUST BE LEFT WITH THE  
HOMEOWNER FOR FUTURE REFERENCE**



This is a safety alert symbol and should never be ignored. When you see this symbol on labels or in manuals, be alert to the potential for personal injury or death.

## CAUTION

As with any mechanical equipment, personal injury can result from contact with sharp sheet metal edges. Be careful when you handle this equipment.

## NOTICE

A thermostat is not included and must be ordered separately.

- The Lennox icomfort Touch™ thermostat must be used in communicating applications.
- In non-communicating applications, the Lennox ComfortSense® 7000 thermostat may be used, as well as other non-communicating thermostats.

In all cases, setup is critical to ensure proper system operation.

Field wiring for both communicating and non-communicating applications is illustrated in diagrams, which begin on Page 32.

## Table of Contents

Unit Dimensions .....	2
G71MPP Parts Arrangement .....	3
Shipping and Packing List .....	4
Safety Information .....	4
Use of Furnace as Construction Heater .....	5
General .....	6
Installation - Setting Equipment .....	6
Filters .....	12
Duct System .....	13
Pipe & Fittings Specifications .....	13
Vent Pipe Sizing Worksheet .....	15
Vent Piping Guidelines .....	16
Joint Cementing Procedure .....	17
Venting Practices .....	18
Gas Piping .....	28

Electrical .....	30
Integrated Control .....	38
Blower Motor Performance .....	45
Unit Start-Up .....	56
Gas Pressure Measurement .....	57
High Altitude Information .....	59
Other Unit Adjustments .....	60
Heating Sequence of Operation .....	61
Service .....	62
Integrated Control Diagnostic Codes .....	65
Configuring Unit Size Codes .....	68
Troubleshooting .....	69
Repair Parts List .....	75
Start-Up & Performance Check List .....	75



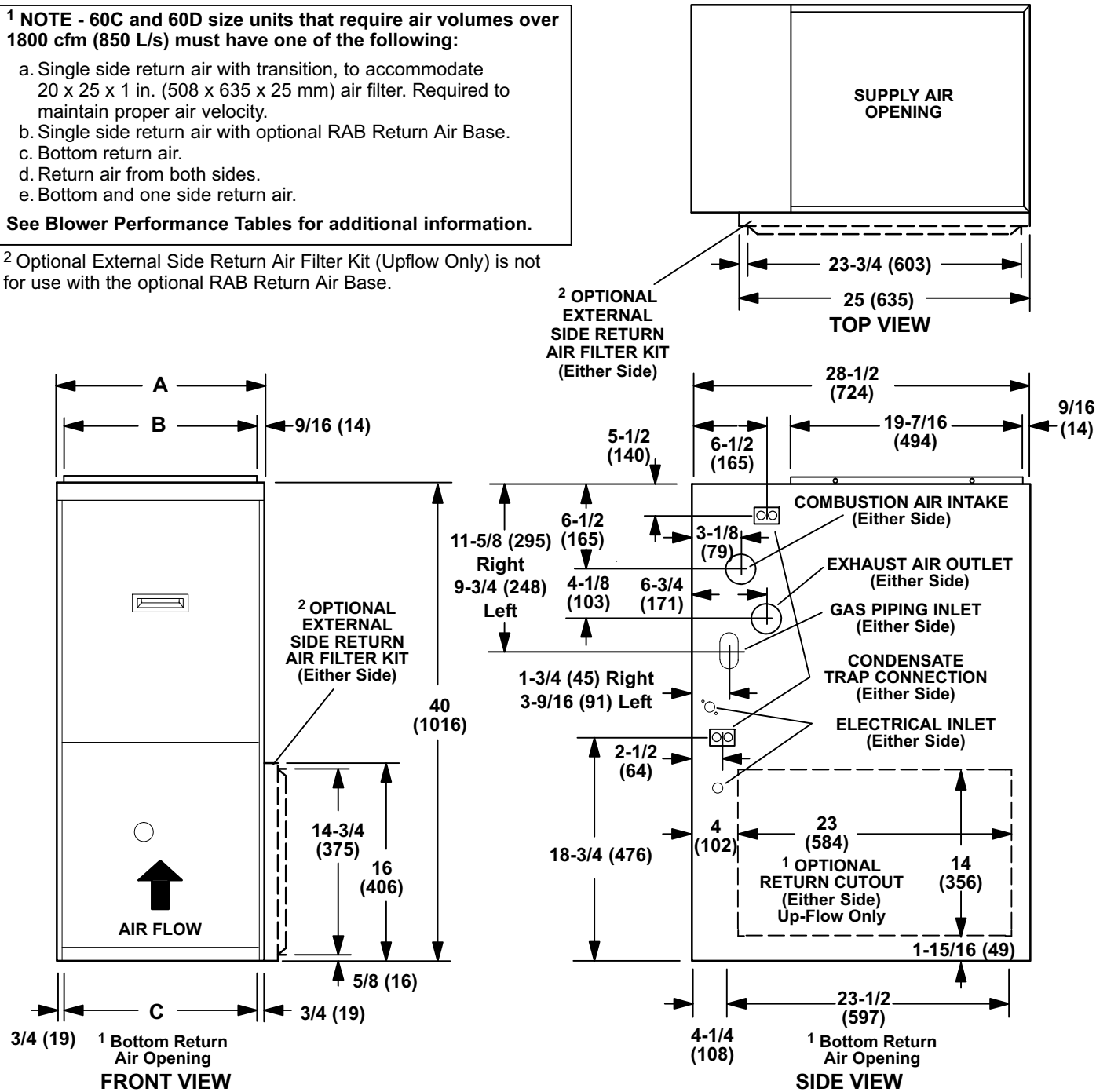
## Unit Dimensions - inches (mm)

<sup>1</sup> NOTE - 60C and 60D size units that require air volumes over 1800 cfm (850 L/s) must have one of the following:

- Single side return air with transition, to accommodate 20 x 25 x 1 in. (508 x 635 x 25 mm) air filter. Required to maintain proper air velocity.
- Single side return air with optional RAB Return Air Base.
- Bottom return air.
- Return air from both sides.
- Bottom and one side return air.

See Blower Performance Tables for additional information.

<sup>2</sup> Optional External Side Return Air Filter Kit (Upflow Only) is not for use with the optional RAB Return Air Base.



Model No.	A		B		C	
	in.	mm	in.	mm	in.	mm
G71MPP-36B-070	17-1/2	446	16-3/8	416	16	406
G71MPP-36C-090 G71MPP-60C-090 G71MPP-60C-110	21	533	19-7/8	505	19-1/2	495
G71MPP-60D-135	24-1/2	622	23-3/8	546	23	584

# G71MPP Parts Arrangement

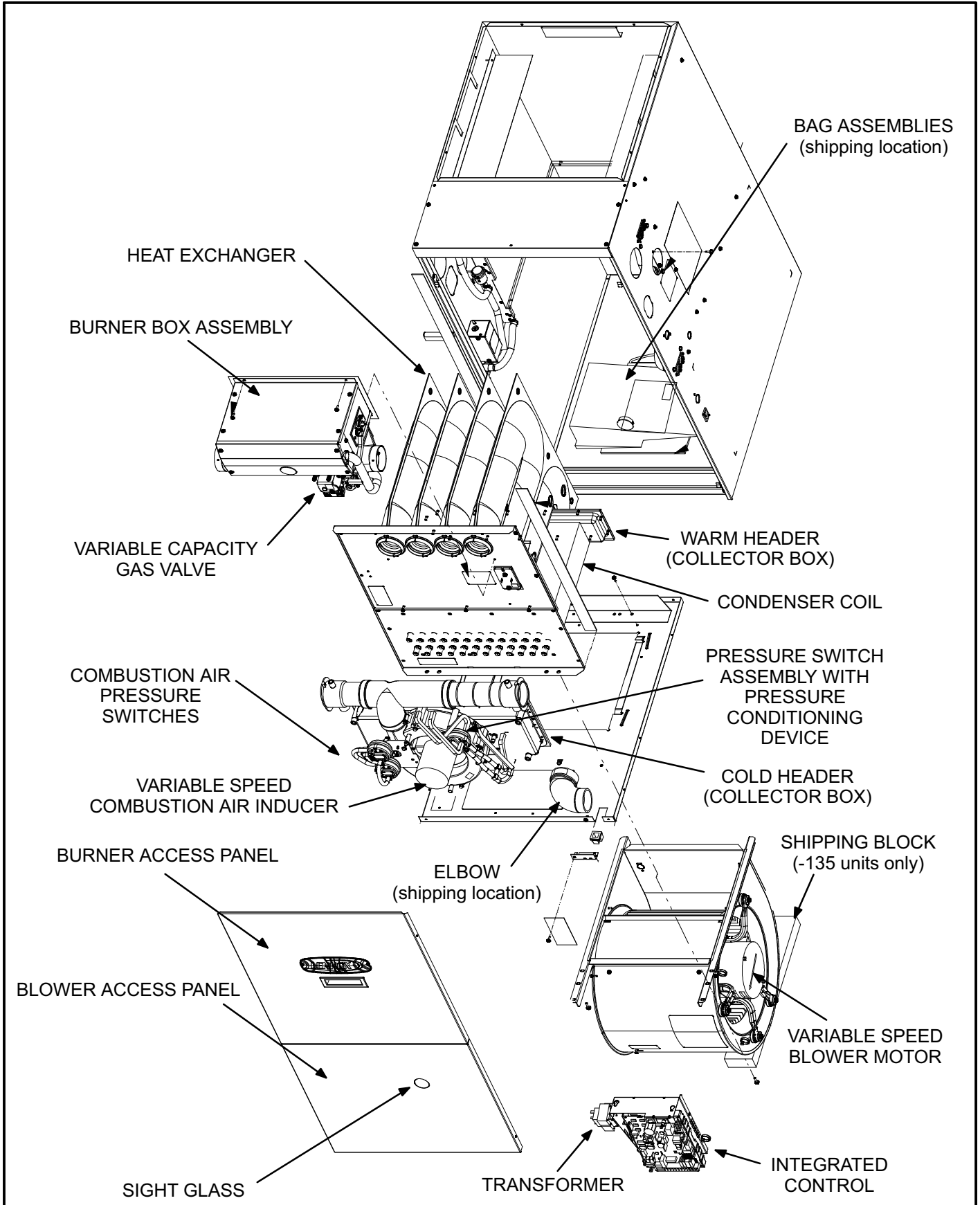


FIGURE 1

## G71MPP Gas Furnace

The G71MPP category IV gas furnace is equipped with a variable-capacity, variable-speed integrated control. This control ensures compatibility with Lennox' Harmony III™ zone control system, as well as a thermostat which provides humidity control. Each G71MPP is shipped ready for installation in the upflow, downflow, horizontal left air discharge or horizontal right air discharge position.

The furnace is equipped for installation in natural gas applications. A conversion kit (ordered separately) is required for use in propane/LP gas applications.

**The G71MPP can be installed only as a Direct Vent gas central furnace.**

**NOTE** - In Direct Vent installations, combustion air is taken from outdoors and flue gases are discharged outdoors. See figure 2 for applications including roof termination.

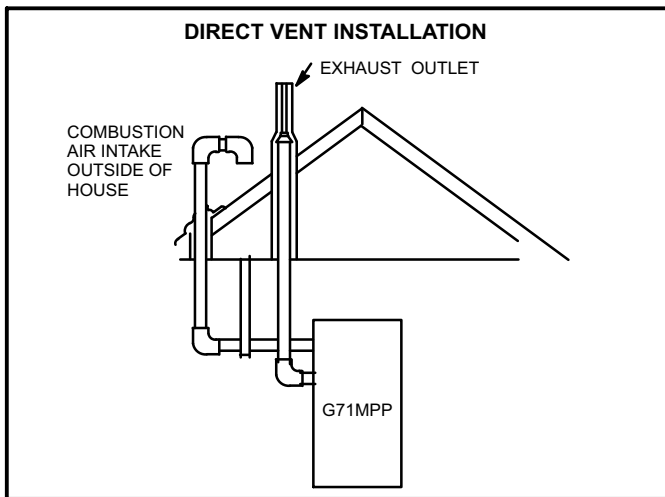


FIGURE 2

## Shipping and Packing List

### Package 1 of 1 contains

- 1 - Assembled G71MPP unit
- 1 - Bag assembly containing the following:
  - 3 - Screws
  - 3 - Wire nuts
  - 1 - Snap bushing
  - 1 - Snap plug
  - 1 - Wire tie
  - 1 - Condensate trap
  - 1 - Condensate trap cap
  - 2 - 2" diameter vent / intake plugs

1 - 3" diameter cabinet plug (intake)

**NOTE** - G71MPP-60C-110 units also include a 2" diameter PVC street elbow, which is shipped on the blower deck in the heating compartment. G71MPP-60D-135 units are shipped with a 3" to 2" PVC reducing elbow.

**Canadian Installations Only** - Replace the provided 2" street elbow shipped with the G71MPP-60C-110 units with 2" street elbow Y0162. Replace the provided 3" X 2" reducing elbow shipped with the G71MPP-60D-135 units with 3" X 2" reducing elbow 40W22. Y0162 and 40W22 meet B149 vent requirements.

Check equipment for shipping damage. If you find any damage, immediately contact the last carrier.

The following items may also be ordered separately:

- 1 - Thermostat
- 1 - Propane/LP changeover kit

## **⚠ DANGER**

### **Danger of explosion.**

**There are circumstances in which odorant used with LP/propane gas can lose its scent. In case of a leak, LP/propane gas will settle close to the floor and may be difficult to smell. An LP/propane leak detector should be installed in all LP applications.**

## **Safety Information**

Use only the type of gas approved for use with this furnace. Refer to unit nameplate.

G71MPP units are CSA International certified to ANSI Z21.47 and CSA 2.3 standards.

In the USA, installation of gas furnaces must conform with local building codes. In the absence of local codes, units must be installed according to the current National Fuel Gas Code (ANSI-Z223.1/NFPA 54). The National Fuel Gas Code is available from the following address:

American National Standards Institute, Inc.  
11 West 42nd Street  
New York, NY 10036

In Canada, installation must conform with current National Standard of Canada CSA-B149 Natural Gas and Propane Installation Codes, local plumbing or waste water codes and other applicable local codes.

This furnace is CSA International certified for installation clearances to combustible material as listed on the unit nameplate and in the tables in figures 4, 9 and 13. Accessibility and service clearances must take precedence over fire protection clearances.

**NOTE** - For installation on combustible floors, the furnace shall not be installed directly on carpeting, tile, or other combustible material other than wood flooring.

For installation in a residential garage, the furnace must be installed so that the burner(s) and the ignition source are located no less than 18 inches (457 mm) above the floor. The furnace must be located or protected to avoid physical damage by vehicles. When a furnace is installed in a public garage, hangar, or other building that has a hazardous atmosphere, the furnace must be installed according to recommended good practice requirements and current National Fuel Gas Code or CSA B149 standard.

**NOTE** - Furnace must be adjusted to obtain a temperature rise within the range specified on the unit nameplate. Failure to do so may cause erratic limit operation.

This G71MPP furnace may be used as a high-static unit heater. The G71MPP may also be installed in an aircraft hangar in accordance with the Standard for Aircraft Hangars (ANSI/NFPA No. 408-1990).

Installation in parking structures must be in accordance with the Standard for Parking Structures (ANSI/NFPA No. 88A-1991). Installation in repair garages must be in accordance with the Standard for Repair Garages (ANSI/NFPA No. 88B-1991).

This G71MPP furnace must be installed so that its electrical components are protected from water.

When this furnace is used with cooling units, it shall be installed in parallel with, or on the upstream side of, cooling units to avoid condensation in the heating compartment. With a parallel flow arrangement, a damper (or other means to control the flow of air) must adequately prevent chilled air from entering the furnace. If the damper is manually operated, it must be equipped to prevent operation of either the heating or the cooling unit, unless it is in the full **HEAT** or **COOL** setting.

When installed, this furnace must be electrically grounded according to local codes. In addition, in the United States, installation must conform with the current National Electric Code, ANSI/NFPA No. 70. The National Electric Code (ANSI/NFPA No. 70) is available from the following address:

National Fire Protection Association  
1 Battery March Park  
Quincy, MA 02269

In Canada, all electrical wiring and grounding for the unit must be installed according to the current regulations of the Canadian Electrical Code Part I (CSA Standard C22.1) and/or local codes.

## CAUTION

**Do not set thermostat below 60°F (16°C) in heating mode. Setting thermostat below 60°F (16°C) reduces the number of heating cycles. Damage to the unit may occur that is not covered by the warranty.**

The G71MPP furnace may be installed in alcoves, closets, attics, basements, garages, and utility rooms.

This furnace design has not been CSA certified for installation in mobile homes, recreational vehicles, or outdoors.

Never use an open flame to test for gas leaks. Check all connections using a commercially available soap solution made specifically for leak detection.

Lennox does not recommend the use of G71MPP units as a construction heater during any phase of construction. Very low return air temperatures, harmful vapors and operation of the unit with clogged or misplaced filters will damage the unit.

### Use of Furnace as Construction Heater

G71MPP units may be used for heating of buildings or structures under construction, if the following conditions are met:

- The vent system must be permanently installed per these installation instructions.
- A room thermostat must control the furnace. The use of fixed jumpers that will provide continuous heating is not allowed.
- The return air duct must be provided and sealed to the furnace.
- Return air temperature range between 60°F (16°C) and 80°F (27°C) must be maintained.
- Air filters must be installed in the system and must be maintained during construction.
- Air filters must be replaced upon construction completion.
- The input rate and temperature rise must be set per the furnace rating plate.
- One hundred percent (100%) outdoor air must be provided for combustion air requirements during construction. Temporary ducting may supply outdoor air to the furnace. Do not connect duct directly to the furnace.
- The furnace heat exchanger, components, duct system, air filters and evaporator coils must be thoroughly cleaned following final construction clean-up.
- All furnace operating conditions (including ignition, input rate, temperature rise and venting) must be verified according to these installation instructions.

## General

### ⚠ WARNING

Product contains fiberglass wool.

Disturbing the insulation in this product during installation, maintenance, or repair will expose you to fiberglass wool. Breathing this may cause lung cancer. (Fiberglass wool is known to the State of California to cause cancer.)

Fiberglass wool may also cause respiratory, skin, and eye irritation.

To reduce exposure to this substance or for further information, consult material safety data sheets available from address shown below, or contact your supervisor.

Lennox Industries Inc.  
P.O. Box 799900  
Dallas, TX 75379-9900

### ⚠ CAUTION

G71MPP unit should not be installed in areas normally subject to freezing temperatures.

These instructions are intended as a general guide and do not supersede local codes in any way. Consult authorities having jurisdiction before installation.

In addition to the requirements outlined previously, the following general recommendations must be considered when installing a G71MPP furnace:

- Place the furnace as close to the center of the air distribution system as possible. The furnace should also be located close to the chimney or vent termination point.
- When the furnace is installed in an attic or other insulated space, keep insulation away from the furnace.
- When the furnace is installed in an unconditioned space, consider provisions required to prevent freezing of condensate drain system.

## Installation - Setting Equipment

### ⚠ WARNING

Do not install the furnace on its front or its back. Do not connect the return air ducts to the back of the furnace. Doing so will adversely affect the operation of the safety control devices, which could result in personal injury or death.

Select a location that allows for the required clearances that are listed on the unit nameplate. Also consider gas supply connections, electrical supply, vent connection, condensate trap and drain connections, and installation and service clearances [24 inches (610 mm) at unit front]. *The unit must be level from side to side. The unit may be tilted slightly (maximum 1/2 in.) from back to front to aid in the draining of the heat exchanger. See figure 3.*

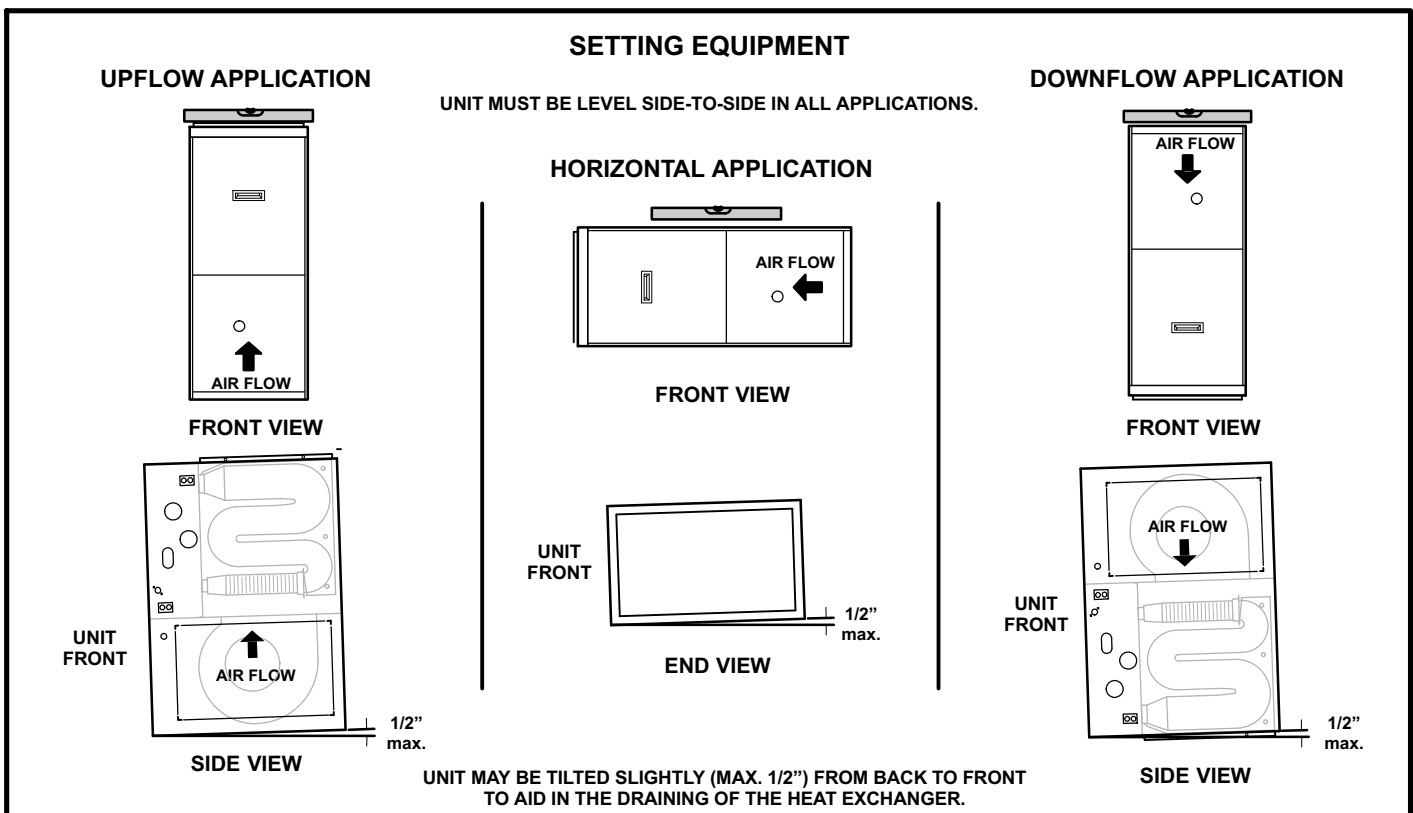


FIGURE 3

**NOTE** - G71MPP-36B and -36C units with 1/2 hp blower motors are equipped with three flexible legs and one rigid leg. The rigid leg is equipped with a shipping bolt and a flat white plastic washer (rather than the rubber mounting grommet used with a flexible mounting leg). **The bolt and washer must be removed before the furnace is placed into operation.** After the bolt and washer have been removed, the rigid leg will not touch the blower housing.

**NOTE** - G71MPP-60D-135 units are equipped with a shipping pad under the blower housing. Remove the shipping pad prior to operation.

Allow for clearances to combustible materials as indicated on the unit nameplate. Minimum clearances for closet or alcove installations are shown in figures 4, 9 and 13.

**⚠ WARNING**

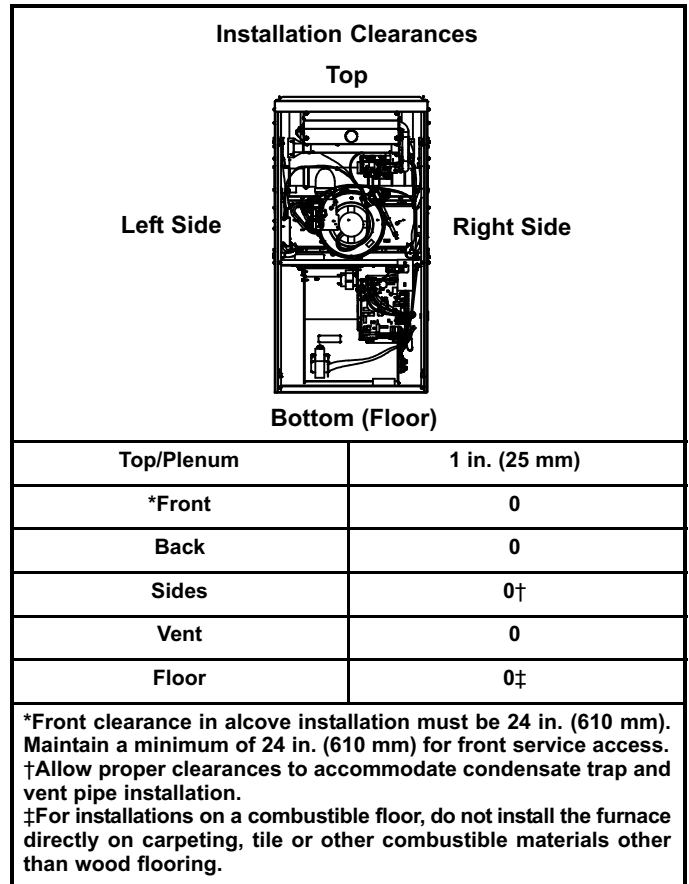
**Blower access panel must be securely in place when blower and burners are operating. Gas fumes, which could contain carbon monoxide, can be drawn into living space resulting in personal injury or death.**

**⚠ WARNING**

**Improper installation of the furnace can result in personal injury or death. Combustion and flue products must never be allowed to enter the return air system or air in the living space. Use sheet metal screws and joint tape to seal return air system to furnace. In platform installations with furnace return, the furnace should be sealed airtight to the return air plenum. A door must never be used as a portion of the return air duct system. The base must provide a stable support and an airtight seal to the furnace. Allow absolutely no sagging, cracks, gaps, etc. For no reason should return and supply air duct systems ever be connected to or from other heating devices such as a fireplace or stove, etc. Fire, explosion, carbon monoxide poisoning, personal injury and/or property damage could result.**

### Upflow Applications

The G71MPP gas furnace can be installed as shipped in the upflow position. Refer to figure 4 for clearances.



**FIGURE 4**

### Return Air -- Upflow Units

Return air can be brought in through the bottom or either side of the furnace installed in an upflow application. If the furnace is installed on a platform with bottom return, make an airtight seal between the bottom of the furnace and the platform to ensure that the furnace operates properly and safely. The furnace is equipped with a removable bottom panel to facilitate installation.

Markings are provided on both sides of the furnace cabinet for installations that require side return air. Cut the furnace cabinet at the maximum dimensions shown on page 2.

**NOTE** - When air volumes over 1800 cfm (850 L/s) are required with 60C or 60D models in an upflow application, the following return air options are available:

- 1 - Return air from single side with transition which will accommodate 20 x 25 x 1 in. (508 x 635 x 25 mm) air filter. (Required to maintain proper air velocity.) See figure 5.

- 2 - Return air from single side with optional RAB Return Air Base. See figure 7.
- 3 - Return air from bottom.
- 4 - Return air from both sides.
- 5 - Return air from bottom and one side.

Refer to Engineering Handbook for additional information.

**G71MPP applications which include side return air and a condensate trap installed on the same side of the cabinet require either a return air base or field-fabricated transition to accommodate an optional IAQ accessory taller than 14.5".**

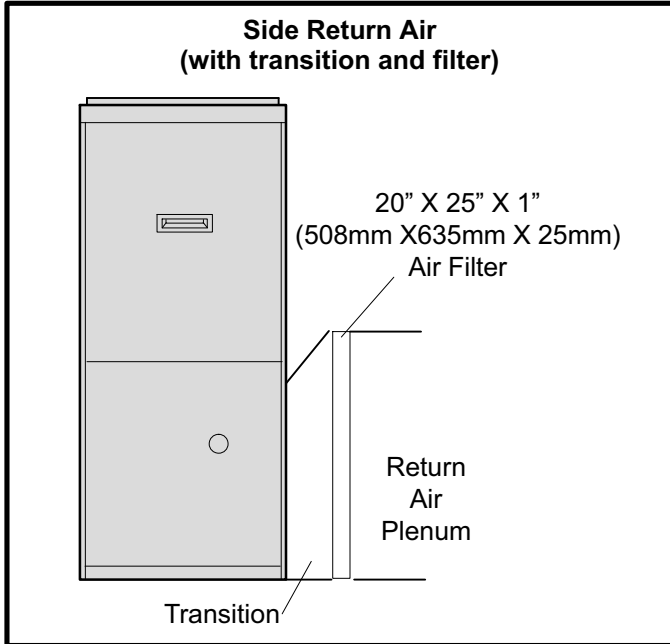


FIGURE 5

**Removing the Bottom Panel**

Remove the two screws that secure the bottom cap to the furnace. Pivot the bottom cap down to release the bottom panel. Once the bottom panel has been removed, reinstall the bottom cap. See figure 6.

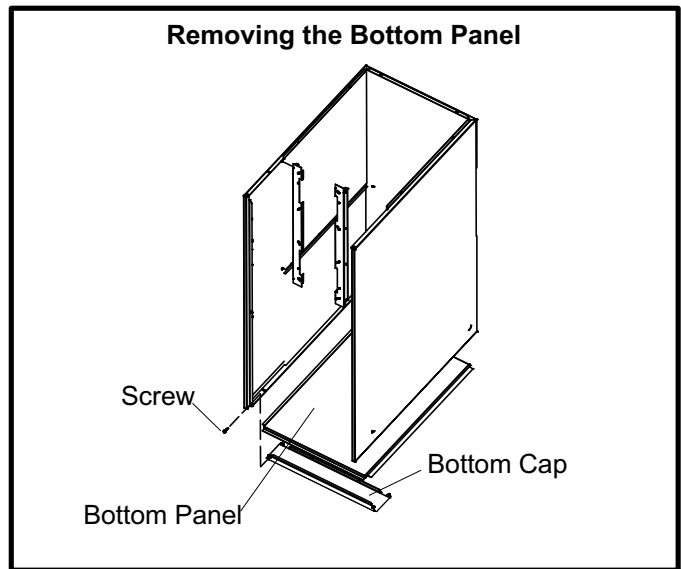


FIGURE 6

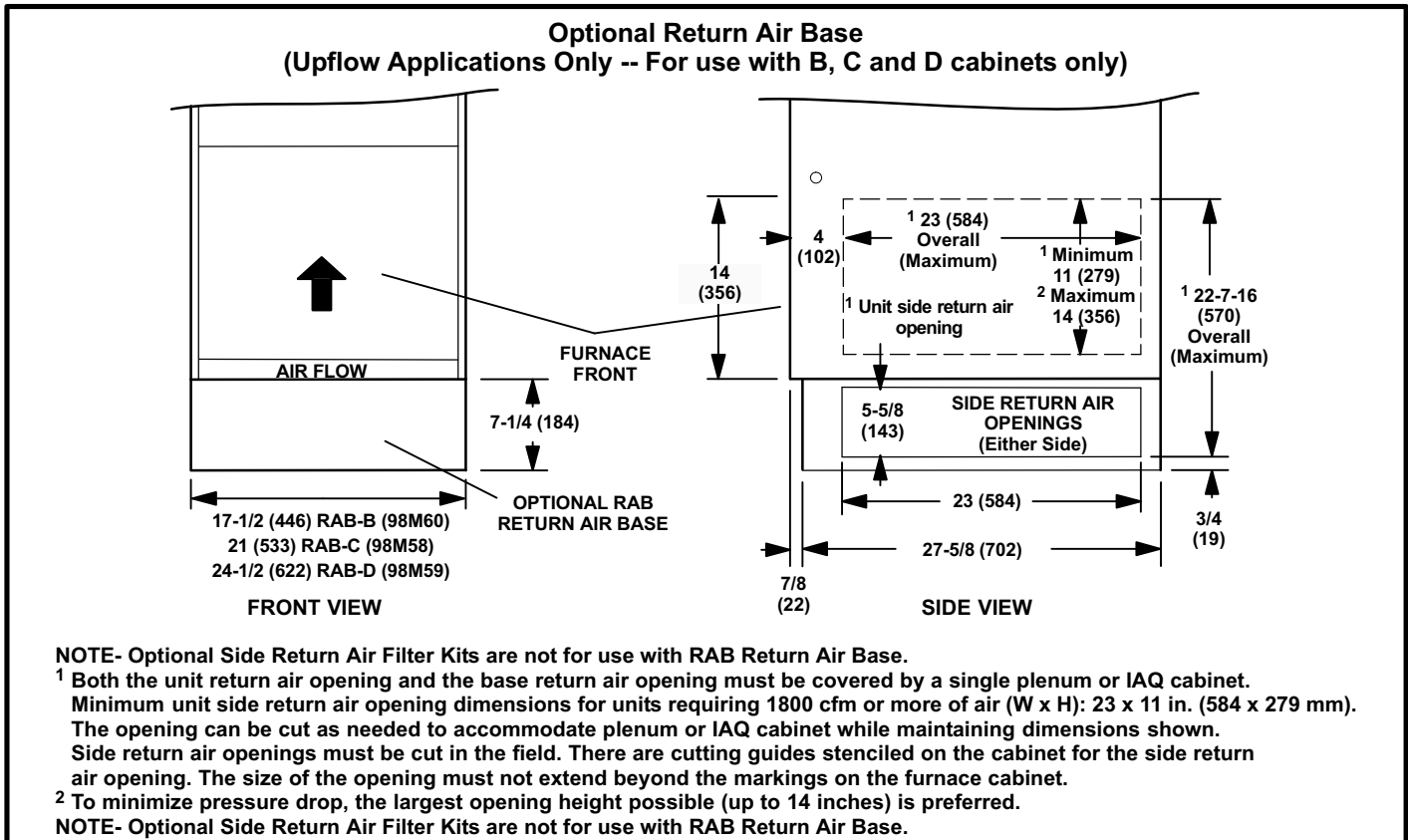


FIGURE 7

NOTE- Optional Side Return Air Filter Kits are not for use with RAB Return Air Base.

<sup>1</sup> Both the unit return air opening and the base return air opening must be covered by a single plenum or IAQ cabinet. Minimum unit side return air opening dimensions for units requiring 1800 cfm or more of air (W x H): 23 x 11 in. (584 x 279 mm). The opening can be cut as needed to accommodate plenum or IAQ cabinet while maintaining dimensions shown.

Side return air openings must be cut in the field. There are cutting guides stenciled on the cabinet for the side return air opening. The size of the opening must not extend beyond the markings on the furnace cabinet.

<sup>2</sup> To minimize pressure drop, the largest opening height possible (up to 14 inches) is preferred.

NOTE- Optional Side Return Air Filter Kits are not for use with RAB Return Air Base.



### Setting an Upflow Unit

When the side return air inlets are used in an upflow application, it may be necessary to install shims on the bottom of the furnace. If desired, use field-supplied corrosion-resistant 5/16 inch machine bolts (4) and nuts (8) to level the furnace. See figure 8.

**NOTE** - The maximum length of the bolt is 1-1/2 inches.

- 1 - Lay the furnace on its back and drill a 5/16 inch diameter hole in each corner of the furnace's bottom. See figure 8 for the correct location of the holes. Drill through the bottom panel and the bottom flange of the cabinet.
- 2 - Install one bolt and two nuts into each hole. Screw the first nut onto a bolt and then insert the bolt into a hole. A flat washer may be added between the nut and the bottom of the unit.
- 3 - Screw another nut onto the bolt on the inside of the furnace base. A flat washer may be added between the nut and the bottom of the unit.
- 4 - Adjust the outside nut to the appropriate height and tighten the inside nut to secure the arrangement.

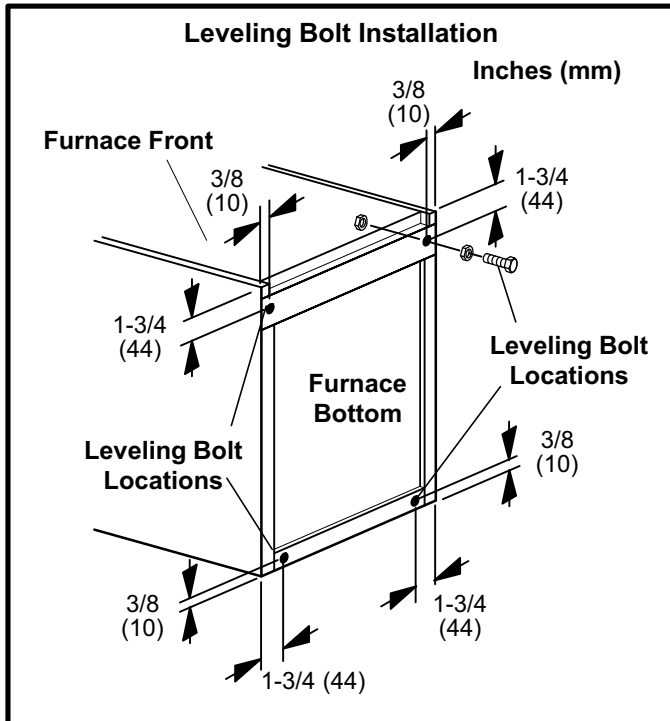


FIGURE 8

### Downflow Applications

The unit may be installed three ways in downflow applications: on non-combustible flooring, on combustible flooring using an additive base, or on a reverse-flow cooling coil cabinet. **Do not drag the unit across the floor in the downflow position. Flange damage will result. Refer to figure 9 for clearances in downflow applications.**

**Downflow Application Installation Clearances**

Top	0
*Front	0
Back	0
Sides	0†
Vent	0
Floor	NC‡

\*Front clearance in alcove installation must be 24 in. (610 mm). Maintain a minimum of 24 in. (610 mm) for front service access.  
 †Allow proper clearances to accommodate condensate trap and vent pipe installation.  
 ‡The furnace may be installed on a combustible wood floor if an optional additive base is installed between the furnace and the combustible floor.

FIGURE 9

### Installation on Non-Combustible Flooring

- 1 - Cut floor opening keeping in mind clearances listed on unit rating plate. Also keep in mind gas supply connections, electrical supply, flue and air intake connections and sufficient installation and servicing clearances. See table 1 for correct floor opening size.
- 2 - Flange warm air plenum and lower the plenum into the opening.
- 3 - Set the unit over the plenum and seal the plenum to the unit.
- 4 - Ensure that the seal is adequate.

**TABLE 1  
NON-COMBUSTIBLE FLOOR OPENING SIZE**

Cabinet Width	Front to Rear		Side to Side	
	in.	mm	in.	mm
B Cabinet (17.5")	19 - 3/4	502	16 - 5/8	422
C Cabinet (21")	19 - 3/4	502	20-1/8	511
D Cabinet (24.5")	19 - 3/4	502	23 - 5/8	600

**NOTE** - Floor opening dimensions listed are 1/4 inch (6 mm) larger than the unit opening. See dimension drawing on page 2.

**Installation on Combustible Flooring  
(Using an Additive Base)**

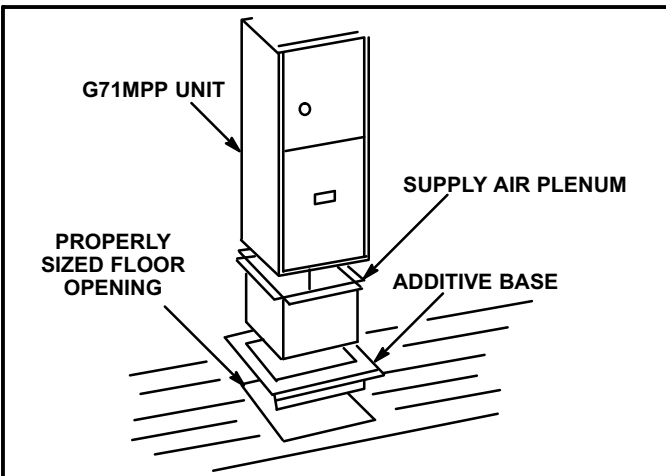
- 1 - When unit is installed on a combustible floor, an additive base must be installed between the furnace and the floor. The base must be ordered separately. See table 2 for opening size to cut in floor.

**⚠ CAUTION**

**The furnace and additive base shall not be installed directly on carpeting, tile, or other combustible material other than wood flooring.**

**TABLE 2  
ADDITIVE BASE FLOOR OPENING SIZE**

Cabinet Width	Catalog Number	Front to Rear		Side to Side	
		in.	mm	in.	mm
B Cabinet (17.5")	11M60	22	559	18 - 3/4	476
C Cabinet (21")	11M61	22	559	22 - 3/4	578
D Cabinet (24.5")	11M62	22	559	25 - 3/4	654



**FIGURE 10**

- 2 - After opening is cut, set additive base into opening.
- 3 - Check fiberglass strips on additive base to make sure they are properly glued and positioned.
- 4 - Lower supply air plenum into additive base until plenum flanges seal against fiberglass strips.

**NOTE** - Be careful not to damage fiberglass strips. Check for a tight seal.

- 5 - Set the furnace over the plenum.
- 6 - Ensure that the seal between the furnace and plenum is adequate.

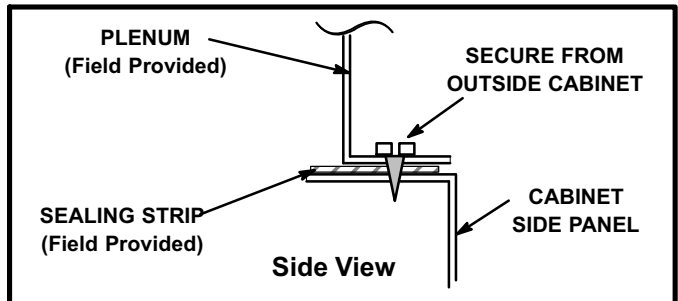
**Installation on Cooling Coil Cabinet**

- 1 - Refer to reverse-flow coil installation instructions for correctly sized opening in floor and installation of cabinet.
- 2 - When cooling cabinet is in place, set and secure the furnace according to the instructions that are provided with the cooling coil. Secure the furnace to the cabinet.
- 3 - Seal the cabinet and check for air leaks.

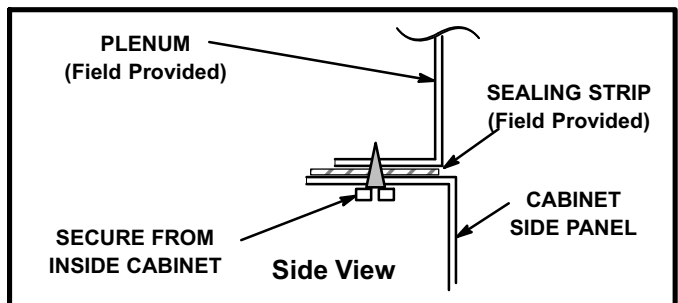
**Return Air Opening -- Downflow Units**

Return air may be brought in only through the top opening of a furnace installed in the downflow position. The following steps should be taken when installing plenum:

- 1 - Bottom edge of plenum should be flanged with a hemmed edge (See figure 11 or 12).
- 2 - Sealing strips should be used to ensure an airtight seal between the cabinet and the plenum.
- 3 - In all cases, plenum should be secured to top of furnace using sheet metal screws.
- 4 - Make certain that an adequate seal is made.



**FIGURE 11**



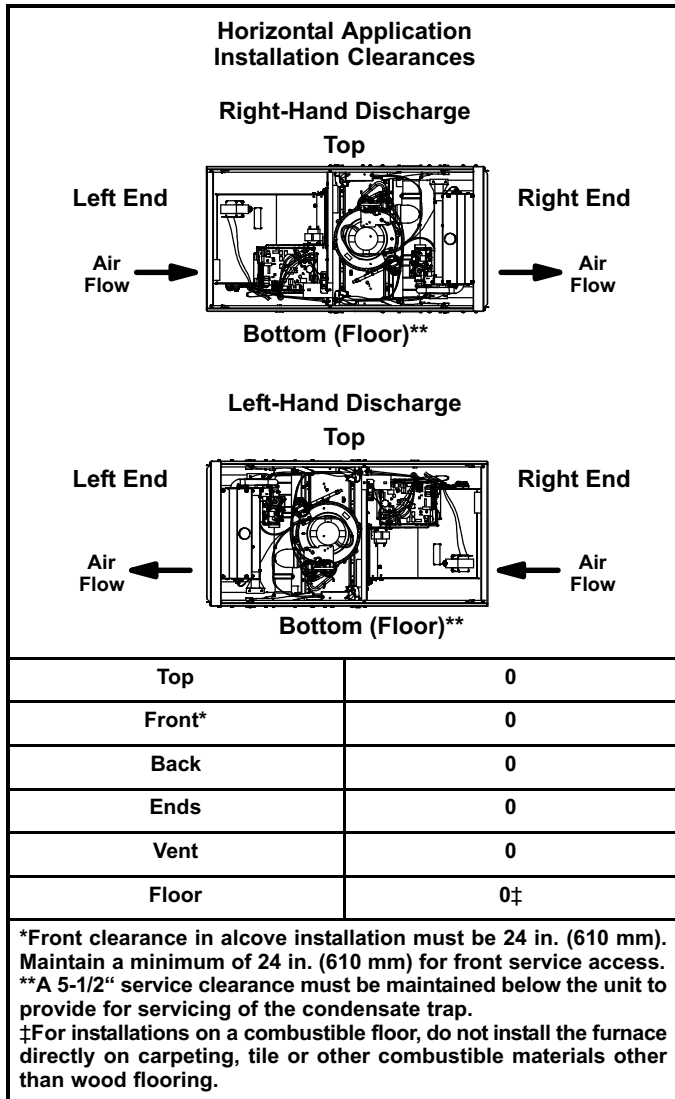
**FIGURE 12**

## Horizontal Applications

The G71MPP furnace can be installed in horizontal applications with either right- or left-hand air discharge.

The G71MPP may also be installed as a unit heater. Either suspend the furnace as shown in figure 14, or install the furnace on a field-fabricated raised platform. The unit must be supported at both ends and beneath the blower deck to prevent sagging.

Refer to figure 13 for clearances in horizontal applications.



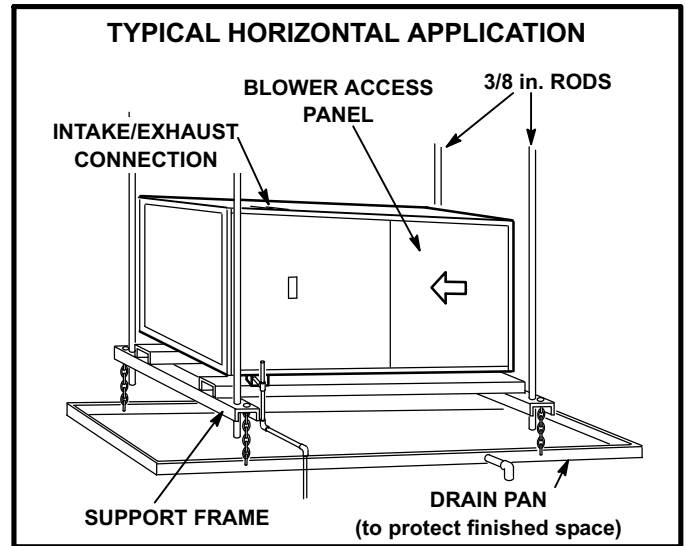
**FIGURE 13**

### Suspended Installation of Horizontal Unit

**NOTE** - If unit is suspended, horizontal support kit (Catalog No. 56J18, ordered separately), or equivalent, is recommended to ensure proper unit support and coil drainage.

- 1 - Select location for unit keeping in mind service and other necessary clearances. See figure 13.
- 2 - Provide service platform in front of unit.

- 3 - If unit is installed above finished space, fabricate a drain pan fitted with a 1/2 inch or 3/4 inch N.P.T. fitting.
- 4 - Using 3/8 inch rods and support frame kit or field-fabricated supports, fabricate suspension hangers, keeping in mind front service access clearances.
- 5 - Mount unit on support frame as shown in figure 14.
- 6 - Continue with exhaust, condensate and intake line piping instructions.



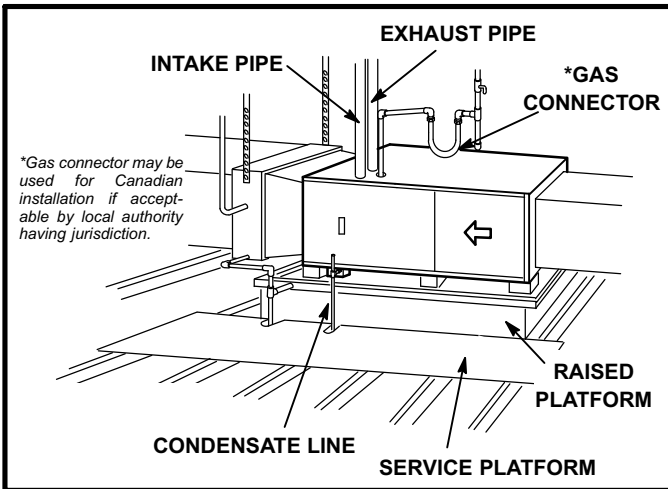
**FIGURE 14**

- 7 - If unit is suspended above finished space, hang the field-provided drain pan below the support frame as shown in figure 14. Leave 5-1/2 inches for service clearance below unit for condensate trap.
- 8 - Route auxiliary drain line so that water draining from this outlet will be easily noticed by the homeowner. If necessary, run the condensate line into a condensate pump to meet drain line slope requirements. The pump must be rated for use with condensing furnaces. Protect the condensate discharge line from the pump to the outside to avoid freezing.

### Platform Installation of Horizontal Unit

- 1 - Select location for unit keeping in mind service and other necessary clearances. See figure 13.
- 2 - Construct a raised wooden frame and cover frame with a plywood sheet. Provide a service platform in front of unit. If unit is installed above finished space, fabricate a drain pan to be installed under unit. When installing the unit in a crawl space, a proper support platform may be created using cement blocks and the horizontal support frame kit (ordered separately,

Lennox part number 56J18). Position the support frame on top of the blocks and install the unit on the frame. Leave 5-1/2 inches for service clearance for condensate trap.



**FIGURE 15**

- 3 - Route auxiliary drain line so that water draining from this outlet will be easily noticed by the homeowner. If necessary, run the condensate line into a condensate pump to meet drain line slope requirements. The pump must be rated for use with condensing furnaces. Protect the condensate discharge line from the pump to the outside to avoid freezing.
- 4 - Set unit in drain pan as shown in figure 15. Leave 5-1/2 inches for service clearance below unit for condensate trap.
- 5 - Continue with exhaust, condensate and intake piping installation according to instructions.

**G71MPP Installed in Unit Heater Applications**

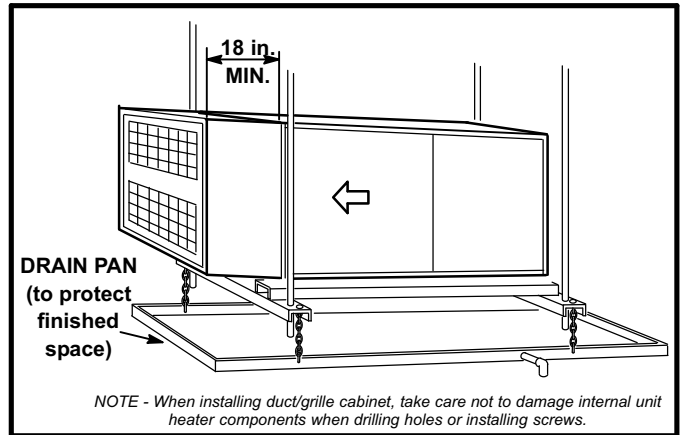
The G71MPP may also be installed as a unit heater. Either suspend the furnace from roof rafters or floor joists, as shown in figure 14, or install the furnace on a field-fabricated raised platform, as shown in figure 15. The unit must be supported at both ends and beneath the blower deck to prevent sagging. The condensate trap must be installed where it can be serviced at a later date.

**Unit Heater Discharge Duct Guidelines**

A field-fabricated and installed discharge air duct and grille cabinet is suitable for use with the G71MPP heater. See figure 16. Keep the following items in mind when constructing the cabinet.

- 1 - Outer dimensions of cabinet should match those of the unit heater, so the duct/grille cabinet installs flush with the unit heater cabinet. See figure 16.

- 2 - Flange both ends of duct/grille cabinet so that screws can be used to secure cabinet to discharge end of unit heater.
- 3 - To ensure proper operation, the duct/grille cabinet must be at least 18 inches long.
- 4 - Use #10-16 x 1/2 inch sheet metal screws to secure duct/grille cabinet to unit, taking care not to damage internal components of unit heater when drilling holes or installing screws. See figure 16.
- 5 - Use adjustable, double-deflection grille(s) to distribute discharge air. Adjust static pressure to be in the 0.06 inch to 0.10 inch w.c. range.



**FIGURE 16**

**Return Air -- Horizontal Applications**

Return air may be brought in only through the end of a furnace installed in the horizontal position. The furnace is equipped with a removable bottom panel to facilitate installation. See figure 6.

**Filters**

This unit is not equipped with a filter or rack. A field-provided filter is required for the unit to operate properly. Table 3 lists recommended filter sizes.

A filter must be in place whenever the unit is operating.

**NOTE** - In upflow applications where side return air filter is installed on same side as the condensate trap, filter rack must be installed beyond condensate trap to avoid interference.

**TABLE 3**

Furnace Cabinet Width	Filter Size	
	Side Return	Bottom Return
B Cabinet (17-1/2")	16 X 25 X 1 (1)	16 X 25 X 1 (1)
C Cabinet (21")	16 X 25 X 1 (1)	20 X 25 X 1 (1)
D Cabinet (24-1/2")	16 X 25 X 1 (2)	24 X 25 X 1 (1)

## Duct System

Use industry-approved standards to size and install the supply and return air duct system. This will result in a quiet and low-static system that has uniform air distribution.

**NOTE** - Operation of this furnace in heating mode (indoor blower operating at selected heating speed) with an external static pressure which exceeds 0.8 inches w.c. may result in erratic limit operation.

### Supply Air Plenum

If the furnace is installed without a cooling coil, a removable access panel should be installed in the supply air duct. The access panel should be large enough to permit inspection (by reflected light) of the heat exchanger for leaks after the furnace is installed. If present, this access panel must always be in place when the furnace is operating and it must not allow leaks into the supply air duct system.

### Return Air Plenum

**Return air must not be drawn from a room where this furnace, or any other gas-fueled appliance (i.e., water heater), or carbon monoxide-producing device (i.e., wood fireplace) is installed.** When return air is drawn from a room, a negative pressure is created in the room. If a gas appliance is operating in a room with negative pressure, the flue products can be pulled back down the vent pipe and into the room. This reverse flow of the flue gas may result in incomplete combustion and the formation of carbon monoxide gas. This toxic gas might then be distributed throughout the house by the furnace duct system.

Return air can be brought in through the bottom or either side of the furnace. If a furnace with bottom return air is installed on a platform, make an airtight seal between the bottom of the furnace and the platform to ensure that the unit operates properly and safely. Use fiberglass sealing strips, caulking, or equivalent sealing method between the plenum and the furnace cabinet to ensure a tight seal. If a filter is installed, size the return air duct to fit the filter frame.

## Pipe & Fittings Specifications

All pipe, fittings, primer and solvent cement must conform with American National Standard Institute and the American Society for Testing and Materials (ANSI/ASTM) stan-

dards. The solvent shall be free flowing and contain no lumps, undissolved particles or any foreign matter that adversely affects the joint strength or chemical resistance of the cement. The cement shall show no gelation, stratification, or separation that cannot be removed by stirring. Refer to table 4 for approved piping and fitting materials.

**TABLE 4  
PIPING AND FITTINGS SPECIFICATIONS**

Schedule 40 PVC (Pipe)	D1785
Schedule 40 PVC (Cellular Core Pipe)	F891
Schedule 40 PVC (Fittings)	D2466
Schedule 40 CPVC (Pipe)	F441
Schedule 40 CPVC (Fittings)	F438
SDR-21 PVC or SDR-26 PVC (Pipe)	D2241
SDR-21 CPVC or SDR-26 CPVC (Pipe)	F442
Schedule 40 ABS Cellular Core DWV (Pipe)	F628
Schedule 40 ABS (Pipe)	D1527
Schedule 40 ABS (Fittings)	D2468
ABS-DWV (Drain Waste & Vent) (Pipe & Fittings)	D2661
PVC-DWV (Drain Waste & Vent) Pipe & Fittings)	D2665
<b>PRIMER &amp; SOLVENT CEMENT</b>	<b>ASTM SPECIFICATION</b>
PVC & CPVC Primer	F656
PVC Solvent Cement	D2564
CPVC Solvent Cement	F493
ABS Solvent Cement	D2235
PVC/CPVC/ABS All Purpose Cement For Fittings & Pipe of the same material	D2564, D2235, F493
ABS to PVC or CPVC Transition Solvent Cement	D3138
<b>CANADA PIPE &amp; FITTING &amp; SOLVENT CEMENT</b>	<b>MARKING</b>
PVC & CPVC Pipe and Fittings	ULCS636
PVC & CPVC Solvent Cement	
ABS to PVC or CPVC Transition Cement	

## CAUTION

**Solvent cements for plastic pipe are flammable liquids and should be kept away from all sources of ignition. Do not use excessive amounts of solvent cement when making joints. Good ventilation should be maintained to reduce fire hazard and to minimize breathing of solvent vapors. Avoid contact of cement with skin and eyes.**

Use PVC primer and solvent cement or ABS solvent cement meeting ASTM specifications, refer to Table 4. As an alternate, use all purpose cement, to bond ABS, PVC, or CPVC pipe when using fittings and pipe made of the same materials. Use transition solvent cement when bonding ABS to either PVC or CPVC.

Low temperature solvent cement is recommended. Metal or plastic strapping may be used for vent pipe hangers. Uniformly apply a liberal coat of PVC primer for PVC or use a clean dry cloth for ABS to clean inside socket surface of fitting and male end of pipe to depth of fitting socket.

**Canadian Applications Only** - Pipe, fittings, primer and solvent cement used to vent (exhaust) this appliance must be certified to ULC S636 and supplied by a single manufacturer as part of an approved vent (exhaust) system. When bonding the vent system to the furnace, use ULC S636 approved One-Step Transition Cement to bond the pipe to the flue collar, or to bond the 90° elbow or reducing 90° elbow to the flue collar. In addition, the first three feet of vent pipe from the furnace flue collar must be accessible for inspection.

Table 5 lists the available exhaust termination kits, as well as vent pipe equivalencies which must be used when sizing vent pipe. All Lennox vent terminations are PVC.

**TABLE 5  
OUTDOOR TERMINATION KITS AND CORRESPONDING EQUIVALENCIES**

UNIT MODEL	VENT PIPE DIA. (in.)	Vent Pipe Length Equivalency (feet)							
		Outdoor Exhaust Accelerator (Dia. X Length)	Outdoor Exhaust Accelerator (Dia. X Length)	1-1/2" Concentric Kit	2" Concentric Kit	3" Concentric Kit	2" Wall Plate Kit	3" Wall Plate Kit	2" Wall Ring Kit
		1-1/2" X 12"	2" X 12"	71M80 or †44W92††	69M29 or †44W92††	60L46 or 44W93†	22G44 or 30G28†	44J40 or 81J20†	15F74
36B-070	2	4	Not Allowed	12	Not Allowed	Not Allowed	4	4*	4
	2-1/2	5	Not Allowed	15	Not Allowed	Not Allowed	5	5*	5
	3	8	Not Allowed	24	Not Allowed	Not Allowed	8	8*	8
	4	14	Not Allowed	42	Not Allowed	Not Allowed	14	14*	14
60C-090	2	Not Allowed	1	Not Allowed	3	3	Not Allowed	1	1**
	2-1/2	Not Allowed	2	Not Allowed	6	6	Not Allowed	2	2**
	3	Not Allowed	2	Not Allowed	6	6	Not Allowed	2	2**
	4	Not Allowed	4	Not Allowed	12	12	Not Allowed	4	4**
60C-110	2-1/2	Not Allowed	2	Not Allowed	6	6	Not Allowed	2	Not Allowed
	3	Not Allowed	2	Not Allowed	6	6	Not Allowed	2	Not Allowed
	4	Not Allowed	4	Not Allowed	12	12	Not Allowed	4	Not Allowed
60D-135	3	Not Allowed	6	Not Allowed	Not Allowed	15	Not Allowed	6	Not Allowed
	4	Not Allowed	10	Not Allowed	Not Allowed	25	Not Allowed	10	No Allowed

\*Requires field-provided and installed 1-1/2" exhaust accelerator.

\*\*Requires field-provided and installed 2" exhaust accelerator.

† Termination kits 44W92, 44W93, 30G28 & 81J20 are ULC-636 approved for Canadian Installation.

†† The 44W92 Concentric kit is provided with a 1-1/2" accelerator which must be installed on the exhaust outlet when this kit is used with the G71MPP-36B-070 furnace.

## Vent Pipe Sizing Worksheet

Step 1	Proposed vent pipe size : _____	Equivalent Feet
Step 2	Termination kit catalog number : _____ Vent pipe equivalency value from table 5 : _____	
Step 3	Total number of 90° elbows required (indoors and outdoors) _____ X 5 = _____ equivalent feet of pipe	
Step 4	Total number of 45° elbows required (indoors and outdoors) _____ X 2.5 = _____ equivalent feet of pipe	
Step 5	Linear feet of straight pipe required : _____	
Step 6	Add equivalent feet of vent pipe listed in steps 2 through 5.	<b>TOTAL</b>

If the total is equal to, or less than, the allowable maximum given in table 7, the proposed pipe size is acceptable. If the total exceeds the maximum allowed vent pipe length, repeat the process above using the next larger diameter pipe until an acceptable total is achieved.

*NOTE - In Direct Vent systems, total the equivalent length of either the exhaust OR intake piping run, depending upon which will be LONGER. Intake and exhaust pipe diameter must be the same size and must be terminated in the same pressure zone. Intake and exhaust pipe should be roughly the same length.*

## Vent Piping Guidelines

The G71MPP can be installed only as a Direct Vent gas central furnace.

**NOTE** - In Direct Vent installations, combustion air is taken from outdoors and flue gases are discharged outdoors.

**Intake and exhaust pipe sizing** -- Size pipe according to tables 6 and 7. Table 6 lists the *minimum* equivalent vent pipe lengths permitted. Table 7 lists the *maximum* equivalent pipe lengths permitted.

**Maximum vent length is defined as:**

Total length (linear feet) of pipe,

**Plus** Equivalent length (feet) of fittings,

**Plus** Equivalent length (feet) of termination.

**NOTE** - Include ALL pipe and ALL fittings, both indoors and outdoors. Measure equivalent length of intake and exhaust pipe separately. Use the greater of the two lengths to determine vent pipe diameter to be used for both intake and exhaust.

Regardless of the diameter of pipe used, the standard roof and wall terminations described in section *Exhaust Piping*

*Terminations* should be used. Exhaust vent termination pipe is sized to optimize the velocity of the exhaust gas as it exits the termination. Refer to table 8.

**NOTE** - The exhaust pipe should be offset a minimum of 12 inches to avoid the possibility of water droplets being released from the exhaust termination. The minimum exhaust vent length is 15 ft. Shorter exhaust vent lengths may result in the discharge of water droplets from the exhaust termination, in spite of the 12-inch vertical offset. See figure 17.

Each 90° elbow (including those provided with the furnace) of any diameter is equivalent to 5 feet (1.52m) of vent pipe of the same diameter. Two 45° elbows are equivalent to one 90° elbow of the same diameter. One 45° elbow is equal to 2.5 feet (.76m) of vent pipe of the same diameter. In some applications which permit the use of several different sizes of vent pipe, a combination vent pipe may be used. Contact Lennox' Application Department for assistance in sizing vent pipe in these applications.

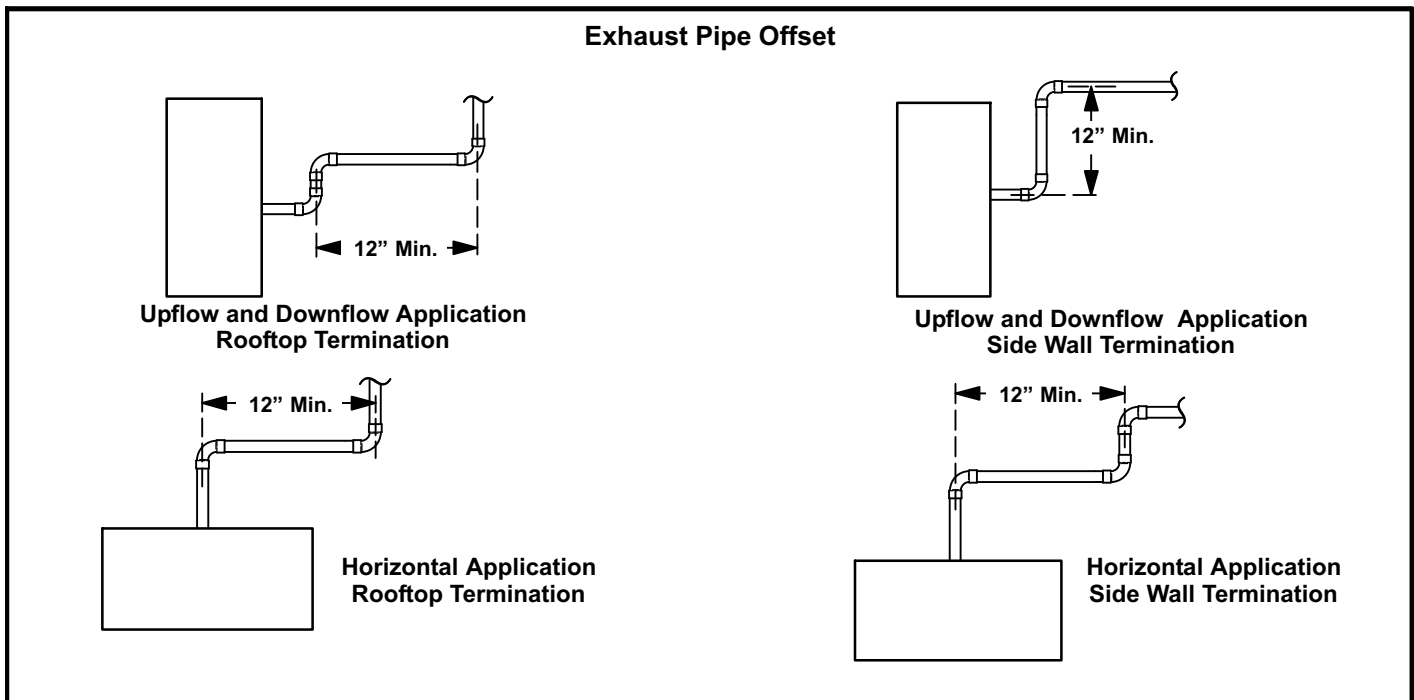


FIGURE 17



**NOTE** - The flue collar on all models is sized to accommodate 2" Schedule 40 flue pipe. When vent pipe which is larger than 2" must be used in an upflow application, a 2" elbow must be applied at the flue collar in order to properly transition to the larger diameter flue pipe. This elbow must be added to the elbow count used to determine acceptable vent lengths. Assign an equivalent feet value to this elbow. Contact the Application Department for more information concerning sizing of vent systems which include multiple pipe sizes.

Use the following steps to correctly size vent pipe diameter. Refer to Vent Pipe Size Determination Worksheet Page 15.

- 1 - Determine the vent termination and its corresponding equivalent feet value according to table 5.
- 2 - Determine the number of 90° elbows required for both indoor and outdoor (e.g. snow riser) use. Calculate the corresponding equivalent feet of vent pipe.
- 3 - Determine the number of 45° elbows required for both indoor and outdoor use. Calculate the corresponding equivalent feet of vent pipe.
- 4 - Determine the length of straight pipe required.
- 5 - Add the total equivalent feet calculated in steps 1 through 4 and compare that length to the maximum values given in table 7 for the proposed vent pipe diameter. If more than one diameter of pipe is being used, use the appropriate value from table 7 for the larger sized pipe. If the total equivalent length required exceeds the maximum equivalent length listed in the appropriate table, evaluate the next larger size pipe.

**⚠ IMPORTANT**

**Do not use screens or perforated metal in exhaust or intake terminations. Doing so will cause freeze-ups and may block the terminations.**

**TABLE 6  
MINIMUM VENT PIPE LENGTHS**

G71MPP MODEL	MIN. EQUIV. VENT LENGTH	EXAMPLE
070, 090	15 ft.*	5 ft. plus 2 elbows of 2", 2-1/2", 3" or 4" diameter pipe
110**		5 ft. plus 2 elbows of 2-1/2" 3" or 4" diameter pipe
135***		5 ft. plus 2 elbows of 3" or 4" diameter pipe

\*Any approved termination may be added to the minimum equivalent length listed.

\*\*G71MPP-60C-110 must have 90° street ell (supplied or field replacement Canadian kit) installed directly into unit flue collar.

\*\*\*G71MPP-60D-135 must have 3" to 2" reducing ell (supplied or field replacement Canadian kit) installed directly into unit flue collar.

**TABLE 7  
MAXIMUM VENT PIPE LENGTHS**

ALTITUDE	G71MPP MODEL	MAXIMUM EQUIVALENT VENT LENGTH FEET			
		2" PIPE	2-1/2" PIPE	3" PIPE	4" PIPE
<b>0 - 7500 (0 - 2286 m)</b>	070	75	135	150	250
	090	50	100	125	225
	110*	20	60	125	200
	135**	n/a	n/a	125	180
<b>7501 - 10000 (2287 - 3048 m)</b>	070	60	125	150	250
	090	25	60	125	225
	110*	n/a	40	90	200
	135**	n/a	n/a	70	180

n/a -- Not allowed.

\*G71MPP-60C-110 must have 90° street ell (supplied or field replacement Canadian kit) installed directly into unit flue collar.

\*\*G71MPP-60D-135 must have 3" to 2" reducing ell (supplied or field replacement Canadian kit) installed directly into unit flue collar.

NOTE - Elbows and pipe required for vent terminations must be added when calculating equivalent vent length.

### Joint Cementing Procedure

All cementing of joints should be done according to the specifications outlined in ASTM D 2855.

⚠ DANGER

DANGER OF EXPLOSION!

Fumes from PVC glue may ignite during system check. Allow fumes to dissipate for at least 5 minutes before placing unit into operation.

- 1 - Measure and cut vent pipe to desired length.
- 2 - Debur and chamfer end of pipe, removing any ridges or rough edges. If end is not chamfered, edge of pipe may remove cement from fitting socket and result in a leaking joint.
- 3 - Clean and dry surfaces to be joined.
- 4 - Test fit joint and mark depth of fitting on outside of pipe.
- 5 - Uniformly apply a liberal coat of PVC primer for PVC or use a clean dry cloth for ABS to clean inside socket surface of fitting and male end of pipe to depth of fitting socket.

**NOTE** - Furnace flue collar and air inlet fitting are both made of ABS material. Use transition solvent cement when joining ABS fittings to PVC pipe.

- 6 - Promptly apply solvent cement to end of pipe and inside socket surface of fitting. Cement should be applied lightly but uniformly to inside of socket. Take care to keep excess cement out of socket. Apply second coat to end of pipe.

**NOTE** - Time is critical at this stage. Do not allow primer to dry before applying cement.

- 7 - Immediately after applying last coat of cement to pipe, and while both inside socket surface and end of pipe are wet with cement, forcefully insert end of pipe into socket until it bottoms out. Turn PVC pipe 1/4 turn during assembly (but not after pipe is fully inserted) to distribute cement evenly. DO NOT turn ABS or cellular core pipe.

**NOTE** - Assembly should be completed within 20 seconds after last application of cement. Hammer blows should not be used when inserting pipe.

- 8 - After assembly, wipe excess cement from pipe at end of fitting socket. A properly made joint will show a bead around its entire perimeter. Any gaps may indicate a defective assembly due to insufficient solvent.
- 9 - Handle joints carefully until completely set.

### Venting Practices

The thickness of construction through which vent pipes may be installed is 24" (610mm) maximum and 3/4" (19mm) minimum. If a G71MPP furnace replaces a furnace which was commonly vented with another gas appliance, the size of the existing vent pipe for that gas appliance must be checked. Without the heat of the original furnace flue products, the existing vent pipe is probably oversized for the single water heater or other appliance. The vent should be checked for proper draw with the remaining appliance.

- 1 - Use recommended piping materials for exhaust piping.
- 2 - Secure all joints so that they are gas-tight using approved cement.

Suspend piping using hangers at a minimum of every 5 feet (1.52m) for schedule 40 PVC and every 3 feet (.91m) for ABS-DWV, PVC-DWV, SPR-21 PVC, and SDR-26 PVC piping. A suitable hanger can be fabricated by using metal or plastic strapping or a large wire tie.

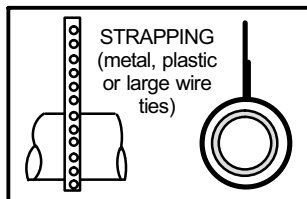


FIGURE 18

- 3 - In areas where piping penetrates joists or interior walls, hole must be large enough to allow clearance on all sides of pipe through center of hole using a hanger.
- 4 - Isolate piping at the point where it exits the outside wall or roof in order to prevent transmission of vibration to the structure.
- 5 - When furnace is installed in a residence where unit is shut down for an extended period of time, such as a vacation home, make provisions for draining condensate collection trap and lines.

### Exhaust Piping (Figures 19 and 20)

**NOTE** - A 2" diameter PVC street ell is located on the blower deck of 60C-110 units. Street ell **must be glued** using transition solvent cement directly into the unit flue collar. See figure 19. A 3" to 2" PVC reducing ell is located on the blower deck of the 60D-135 units. **In upflow or downflow applications, the reducing ell must be glued** using transition solvent cement directly into the unit flue collar.

- 1 - Choose the appropriate side for venting in upflow or downflow positions. Exhaust piping exits from the top of the unit in horizontal air discharge applications. Glue the field-provided exhaust vent pipe (or provided street ell or reducing ell in upflow or downflow applications) to the flue collar. All PVC cement joints should be made according to the specifications outlined in ASTM D 2855. Refer to pipe and fittings specifications and gluing procedures.

### ⚠ IMPORTANT

**Exhaust piping and condensate trap must be installed on the same side of the unit in upflow and downflow applications or use alternate drain kit 76M20.**

- 2 - All horizontal runs of exhaust pipe must slope back toward unit. A minimum of 1/4" (6mm) drop for each 12" (305mm) of horizontal run is mandatory for drainage. Horizontal runs of exhaust piping must be supported every 5 feet (1.52m) using hangers.

**NOTE** - Exhaust piping should be checked carefully to make sure there are no sags or low spots.

- 3 - On the opposite side of the cabinet, glue the provided 2" ABS vent plug into the unused ABS flue collar with ABS or all purpose solvent cement.
- 4 - Route piping to outside of structure. Continue with installation following instructions given in piping termination section.

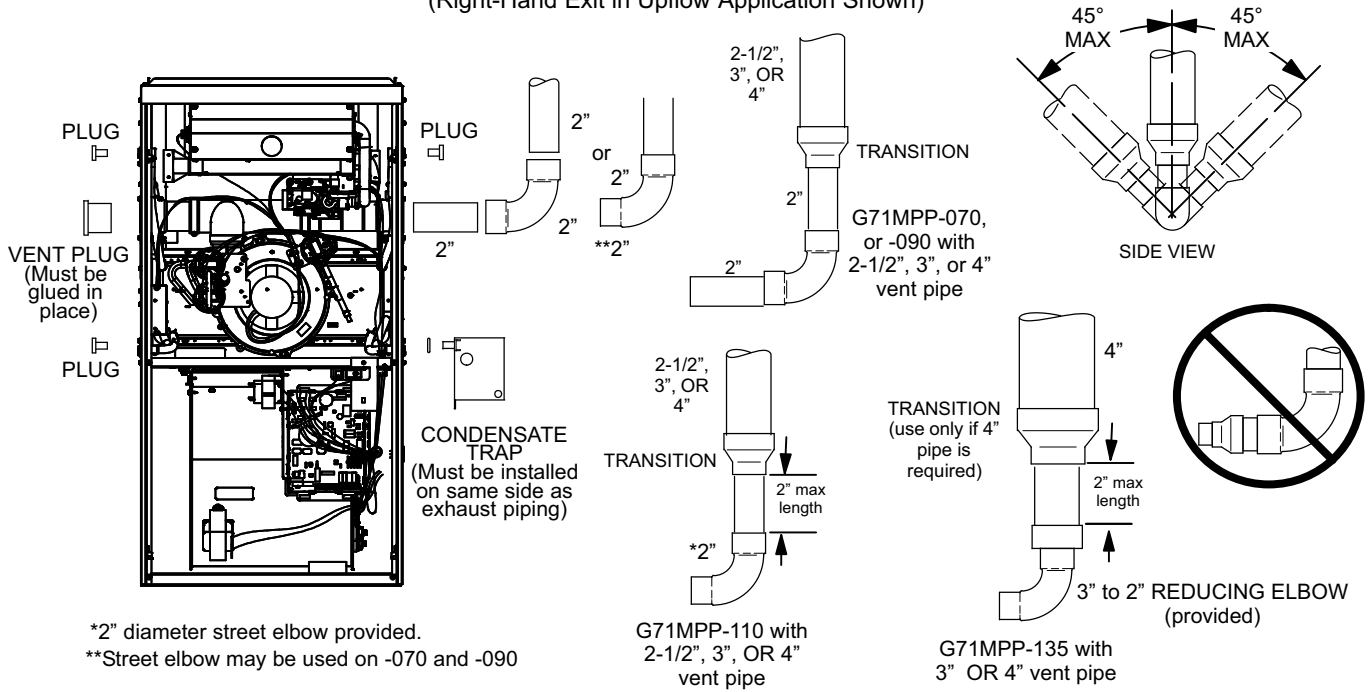
### ⚠ CAUTION

**Do not discharge exhaust into an existing stack or stack that also serves another gas appliance. If vertical discharge through an existing unused stack is required, insert PVC pipe inside the stack until the end is even with the top or outlet end of the metal stack.**

### ⚠ CAUTION

**The exhaust vent pipe operates under positive pressure and must be completely sealed to prevent leakage of combustion products into the living space.**

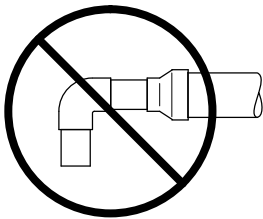
**TYPICAL EXHAUST PIPE CONNECTIONS AND CONDENSATE TRAP INSTALLATION**  
 IN UPFLOW OR DOWNFLOW DIRECT VENT APPLICATIONS  
 (Right-Hand Exit in Upflow Application Shown)



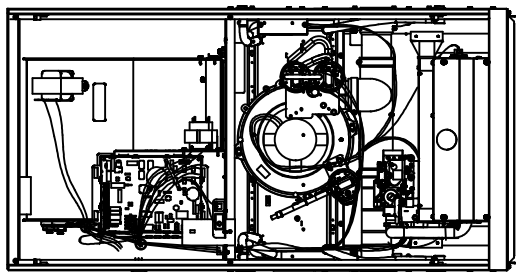
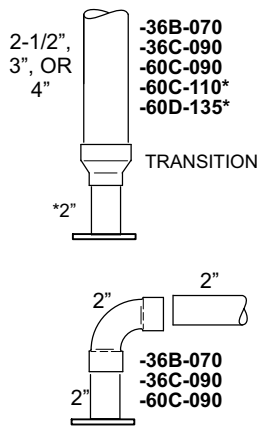
**FIGURE 19**

**TYPICAL EXHAUST PIPE CONNECTIONS**  
 HORIZONTAL DIRECT VENT APPLICATIONS  
 (Horizontal Right-Hand Air Discharge Application Shown)

\*2" maximum length for -110 and -135 only.



**DO NOT transition from smaller to larger pipe size in horizontal runs of exhaust pipe.**

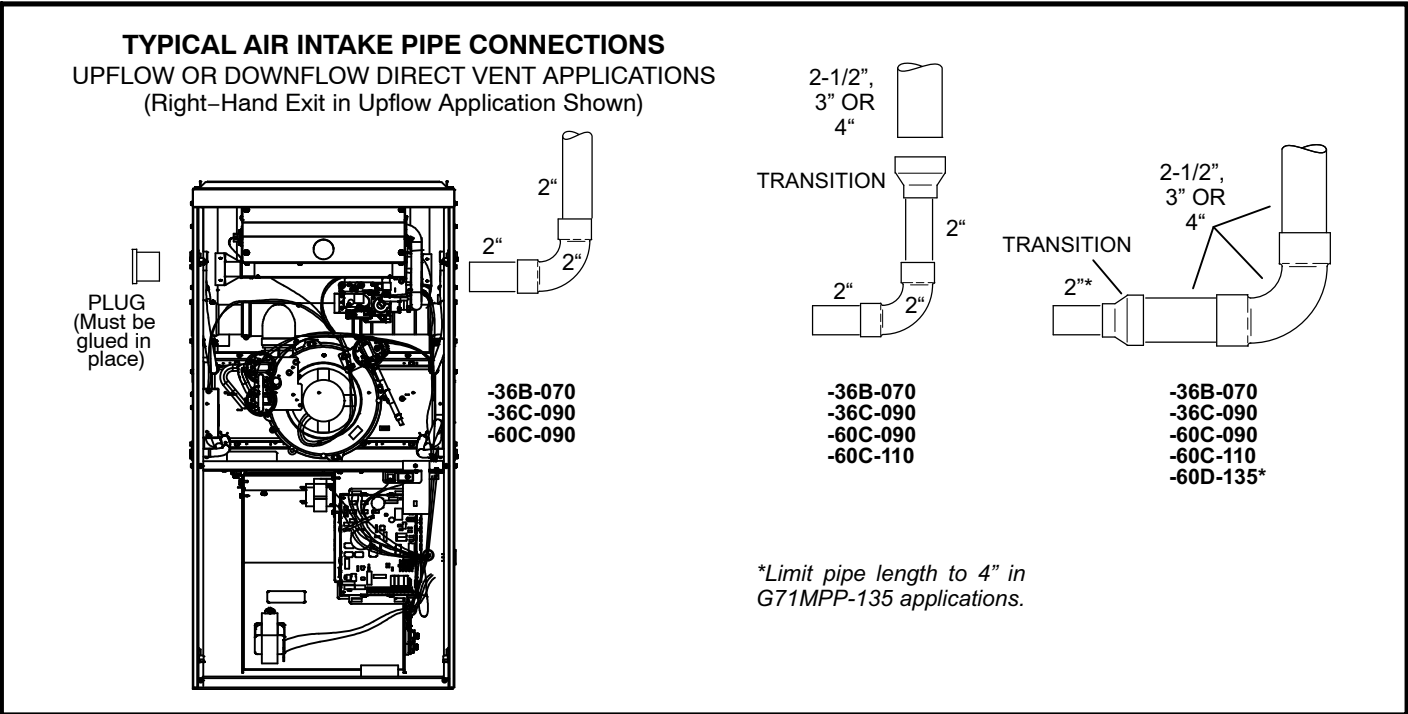


**FIGURE 20**

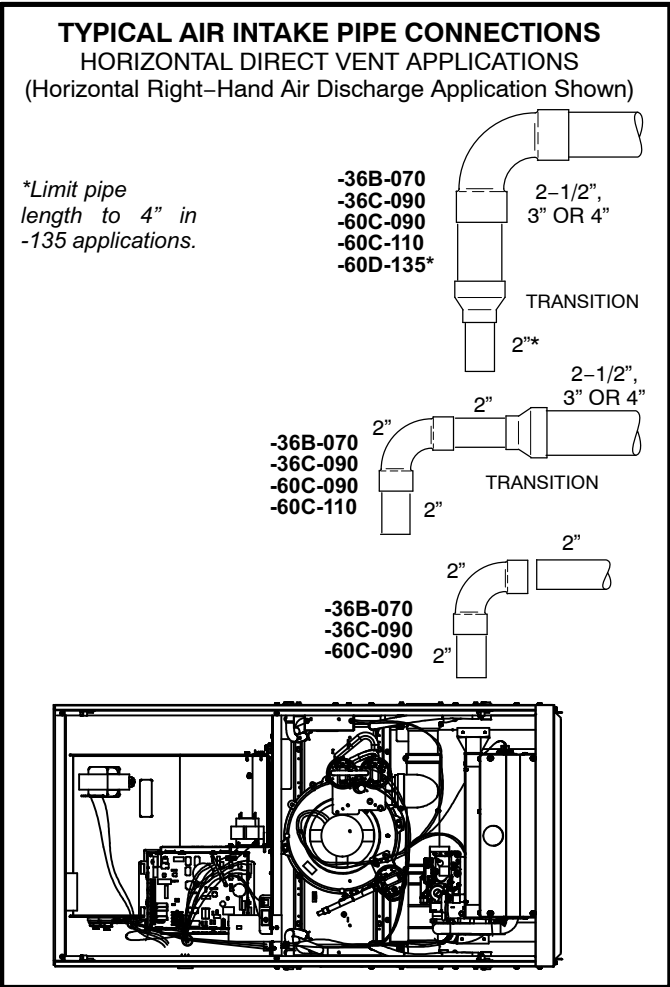
**Intake Piping**

The G71MPP furnace may be installed only in **direct vent** applications.

The G71MPP unit is designed for either left-side or right-side air intake connections in either upflow or downflow applications. In horizontal applications, air intake must be brought in through the top. Intake air piping is independent of exhaust piping.

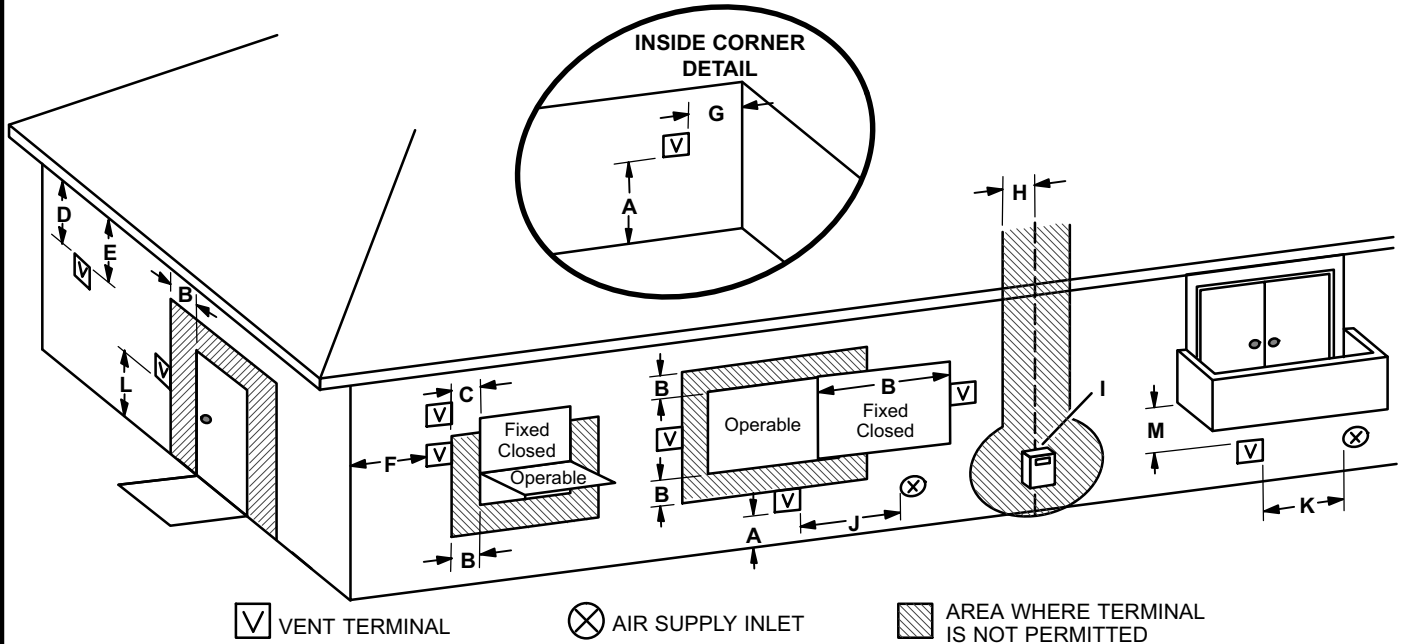


**FIGURE 21**



**FIGURE 22**

## VENT TERMINATION CLEARANCES FOR DIRECT VENT INSTALLATIONS IN THE USA AND CANADA



	US Installations <sup>1</sup>	Canadian Installations <sup>2</sup>	
A =	Clearance above grade, veranda, porch, deck or balcony	12 inches (305mm) or 12 in. 305mm above average snow accumulation.	12 inches (305mm) or 12 in. 305mm above average snow accumulation.
B =	Clearance to window or door that may be opened	6 inches (152mm) for appliances <10,000 Btuh (3kw), 9 inches (mm) for appliances > 10,000 Btuh (3kw) and <50,000 Btuh (15 kw), 12 inches (305mm) for appliances > 50,000 Btuh (15kw)	6 inches (152mm) for appliances <10,000 Btuh (3kw), 12 inches (305mm) for appliances > 10,000 Btuh (3kw) and <100,000 Btuh (30kw), 36 inches (.9m) for appliances > 100,000 Btuh (30kw)
C =	Clearance to permanently closed window	* 12"	* 12"
D =	Vertical clearance to ventilated soffit located above the terminal within a horizontal distance of 2 feet (mm) from the center line of the terminal	* Equal to or greater than soffit depth	* Equal to or greater than soffit depth
E =	Clearance to unventilated soffit	* Equal to or greater than soffit depth	* Equal to or greater than soffit depth
F =	Clearance to outside corner	* No minimum to outside corner	* No minimum to outside corner
G =	Clearance to inside corner	* 3 feet (.9m)	* 3 feet (.9m)
H =	Clearance to each side of center line extended above meter / regulator assembly	3 feet (.9m) within a height 15 feet (4.5m) above the meter / regulator assembly	3 feet (.9m) within a height 15 feet (4.5m) above the meter / regulator assembly
I =	Clearance to service regulator vent outlet	* 3 feet (.9m)	3 feet (.9m)
J =	Clearance to non-mechanical air supply inlet to building or the combustion air inlet to any other appliance	6 inches (152mm) for appliances <10,000 Btuh (3kw), 9 inches (mm) for appliances > 10,000 Btuh (3kw) and <50,000 Btuh (15 kw), 12 inches (305mm) for appliances > 50,000 Btuh (15kw)	6 inches (152mm) for appliances <10,000 Btuh (3kw), 12 inches (305mm) for appliances > 10,000 Btuh (3kw) and <100,000 Btuh (30kw), 36 inches (.9m) for appliances > 100,000 Btuh (30kw)
K =	Clearance to mechanical air supply inlet	3 feet (.9m) above if within 10 feet (3m) horizontally	6 feet (1.8m)
L =	Clearance above paved sidewalk or paved driveway located on public property	* 7 feet (2.1m)	7 feet (2.1m)†
M =	Clearance under veranda, porch, deck or balcony	*12 inches (305mm)‡	12 inches (305mm)‡

<sup>1</sup> In accordance with the current ANSI Z223.1/NFPA 54 Natural Fuel Gas Code

<sup>2</sup> In accordance with the current CSA B149.1, Natural Gas and Propane Installation Code

† A vent shall not terminate directly above a sidewalk or paved driveway that is located between two single family dwellings and serves both dwellings.

‡ Permitted only if veranda, porch, deck or balcony is fully open on a minimum of two sides beneath the floor. Lennox recommends avoiding this location if possible.

\*For clearances not specified in ANSI Z223.1/NFPA 54 or CSA B149.1, clearance will be in accordance with local installation codes and the requirements of the gas supplier and these installation instructions."

**FIGURE 23**

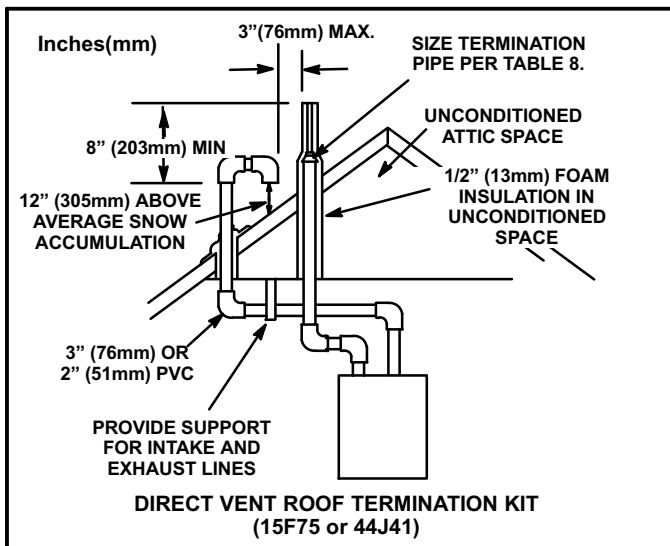
**Details of Intake and Exhaust Piping Terminations for Direct Vent Installation**

**NOTE** - In Direct Vent installations, combustion air is taken from outdoors and flue gases are discharged to outdoors.

Intake and exhaust pipes may be routed either horizontally through an outside wall or vertically through the roof. In attic or closet installations, vertical termination through the roof is preferred. Figures 24 through 34 show typical terminations.

- 1 - Exhaust and intake exits must be in same pressure zone. Do not exit one through the roof and one on the side. Also, do not exit the intake on one side and the exhaust on another side of the house or structure.
- 2 - Intake and exhaust pipes should be placed as close together as possible at termination end (refer to illustrations). Maximum separation is 3" (76mm) on roof terminations and 6" (152mm) on side wall terminations.
- 3 - On roof terminations, the intake piping should terminate straight down using two 90° elbows (See figure 24).
- 4 - Exhaust piping must terminate straight out or up as shown. A reducer may be required on the exhaust piping at the point where it exits the structure to improve the velocity of exhaust away from the intake piping. See table 8.

**NOTE** - Care must be taken to avoid recirculation of exhaust back into intake pipe.



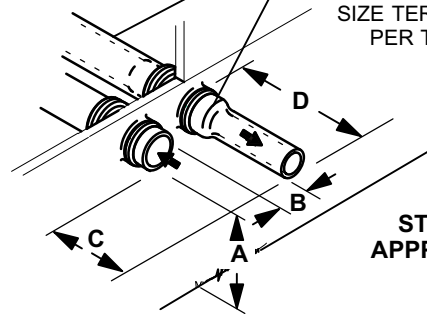
**FIGURE 24**

**FIELD SUPPLIED WALL TERMINATION OR (15F74) WALL RING TERMINATION KIT**

NOTE - FIELD PROVIDED REDUCER MAY BE REQUIRED TO ADAPT LARGER VENT PIPE SIZE TO TERMINATION

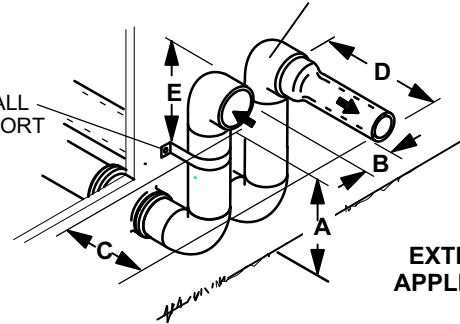
1/2" (13mm) ARMAFLEX INSULATION IN UNCONDITIONED SPACE

SIZE TERMINATION PER TABLE 8



1/2" (13mm) ARMAFLEX INSULATION IN UNCONDITIONED SPACE

\* WALL SUPPORT



See venting table 7 for maximum venting lengths with this arrangement.

\* Use wall support every 24" (610 mm). Use two wall supports if extension is greater than 24" (610 mm) but less than 48" (1219 mm). NOTE - One wall support must be 6" (152 mm) from top of each pipe (intake and exhaust)

	2" (51mm) Vent Pipe	3" (76mm) Vent Pipe
<b>A</b> -Minimum clearance above grade or average snow accumulation	12" (508MM)	12" (508MM)
<b>B</b> -Maximum horizontal separation between intake and exhaust	6" (152MM)	6" (152MM)
<b>C</b> -Minimum from end of exhaust to inlet of intake	8" (203MM)	8" (203MM)
<b>D</b> -Maximum exhaust pipe length	12" (305MM)	20" (508MM)
<b>E</b> -Maximum wall support distance from top of each pipe (intake/exhaust)	6" (152MM)	6" (152MM)

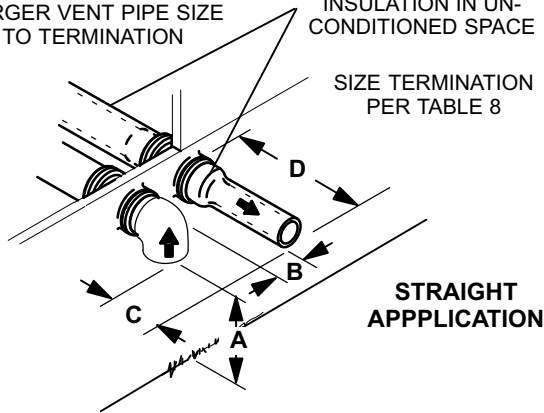
**FIGURE 25**

**FIELD SUPPLIED WALL TERMINATION OR (15F74) WALL RING TERMINATION KIT With INTAKE ELBOW**

NOTE - FIELD PROVIDED REDUCER MAY BE REQUIRED TO ADAPT LARGER VENT PIPE SIZE TO TERMINATION

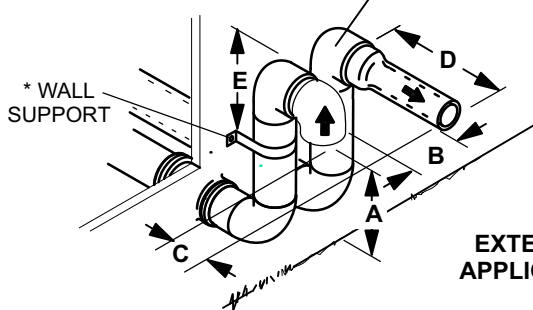
1/2" (13mm) ARMAFLEX INSULATION IN UN-CONDITIONED SPACE

SIZE TERMINATION PER TABLE 8



**STRAIGHT APPLICATION**

1/2" (13mm) ARMAFLEX INSULATION IN UNCONDITIONED SPACE



**EXTENDED APPLICATION**

See venting table 7 for maximum venting lengths with this arrangement.

\* Use wall support every 24" (610 mm). Use two wall supports if extension is greater than 24" (610 mm) but less than 48" (1219 mm). NOTE - One wall support must be 6" (152 mm) from top of each pipe (intake and exhaust)

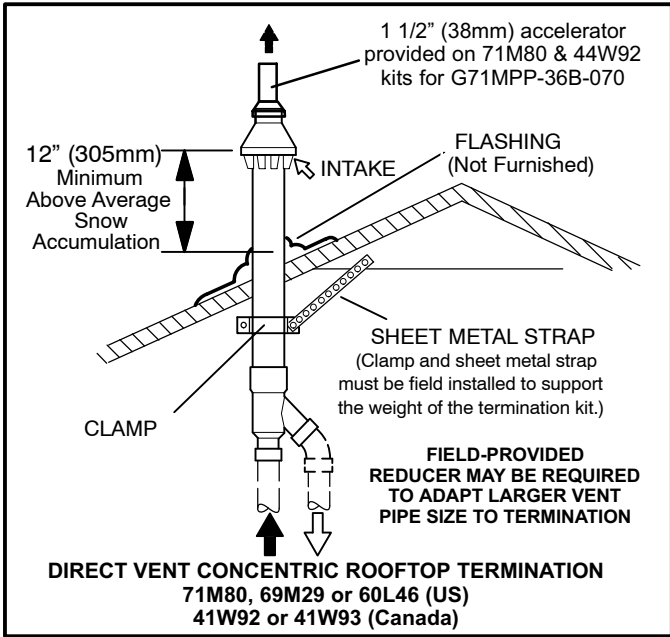
	<b>2" (51mm) Vent Pipe</b>	<b>3" (76mm) Vent Pipe</b>
<b>A</b> -Minimum clearance above grade or average snow accumulation	12" (508MM)	12" (508MM)
<b>B</b> -Maximum horizontal separation between intake and exhaust	6" (152MM)	6" (152MM)
<b>C</b> -Minimum from end of exhaust to inlet of intake	6" (152MM)	6" (152MM)
<b>D</b> -Maximum exhaust pipe length	12" (305MM)	20" (508MM)
<b>E</b> -Maximum wall support distance from top of each pipe (intake/exhaust)	6" (152MM)	6" (152MM)

**FIGURE 26**

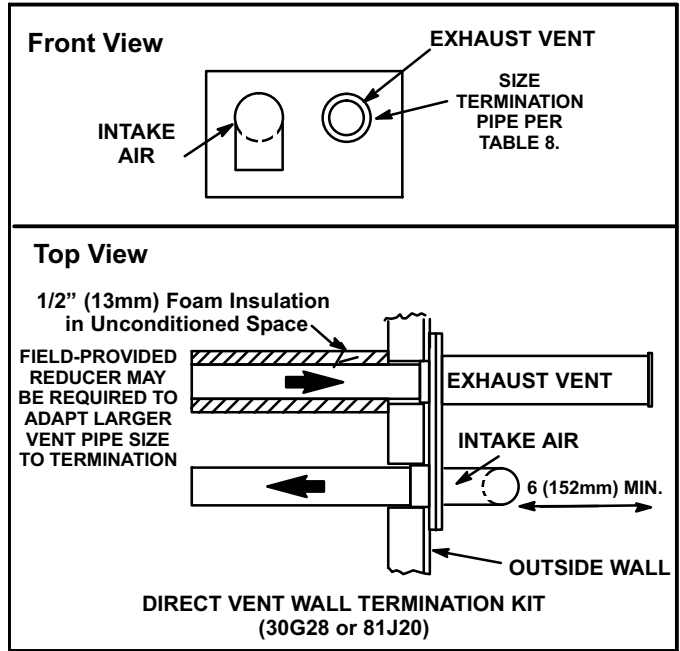
**TABLE 8 EXHAUST PIPE TERMINATION SIZE REDUCTION**

<b>G71MPP MODEL</b>	<b>Exhaust Pipe Size</b>	<b>Termination Pipe Size</b>
070	2" (51mm), 2-1/2" (64mm), 3" (76mm) or 4" (102mm)	1-1/2" (38mm)
090		2" (51mm)
110		2" (51mm)
135	3" (76mm) or 4" (102mm)	2" (51mm)

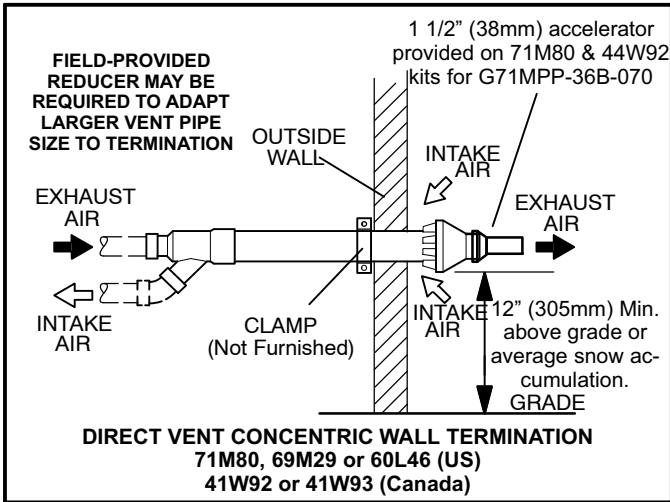
- 5 - On field supplied terminations for side wall exit, exhaust piping may extend a maximum of 12 inches (305mm) for 2" PVC and 20 inches (508mm) for 3" (76mm) PVC beyond the outside wall. Intake piping should be as short as possible. See figures 25 and 26.
- 6 - On field supplied terminations, a minimum distance between the end of the exhaust pipe and the end of the intake pipe without a termination elbow is 8" and a minimum distance of 6" with a termination elbow. See figures 25 and 26.
- 7 - If intake and exhaust piping must be run up a side wall to position above snow accumulation or other obstructions, piping must be supported every 24" (610mm) as shown in figures 25 and 26. In addition, close coupled wall termination kits must be extended for use in this application. See figures 32 and 33. When exhaust and intake piping must be run up an outside wall, the exhaust piping must be terminated with pipe sized per table 8. The intake piping may be equipped with a 90° elbow turndown. Using turndown will add 5 feet (1.5m) to the equivalent length of the pipe.
- 8 - Based on the recommendation of the manufacturer, a multiple furnace installation may use a group of up to four terminations assembled together horizontally, as shown in figure 29.



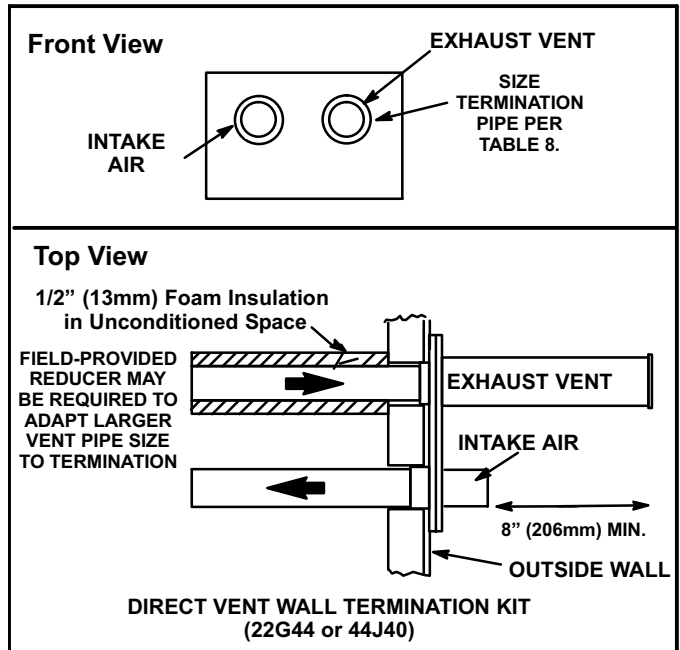
**FIGURE 27**



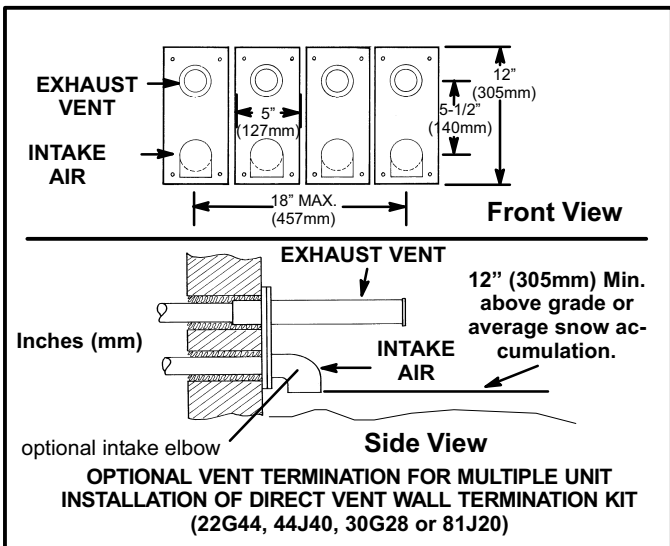
**FIGURE 30**



**FIGURE 28**



**FIGURE 31**

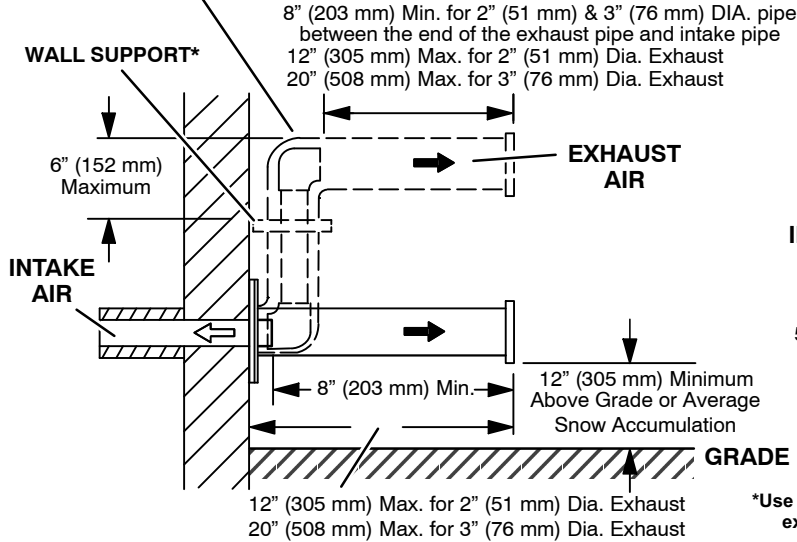


**FIGURE 29**

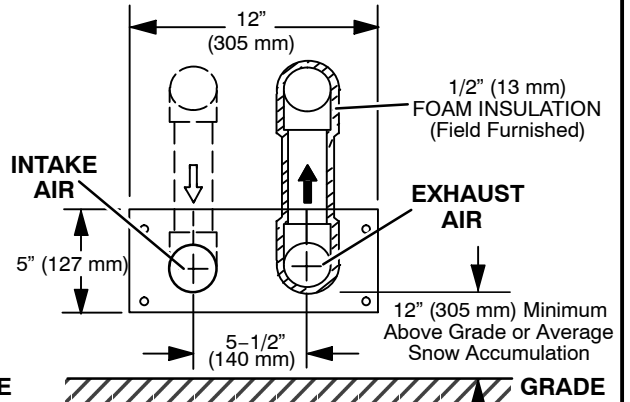


**WALL TERMINATION KITS (CLOSE-COUPLE)  
EXTENDED VENT FOR GRADE CLEARANCE  
2 inch (51 mm) 22G44 (US)  
3 inch (76 mm) 44J40 (US)**

If Intake and Exhaust Pipe is less than 12 in. (305 mm) above snow accumulation or other obstructions, field fabricated piping must be installed.



**FIELD-PROVIDED  
REDUCER MAY BE REQUIRED TO ADAPT  
LARGER VENT PIPE SIZE TO TERMINATION**



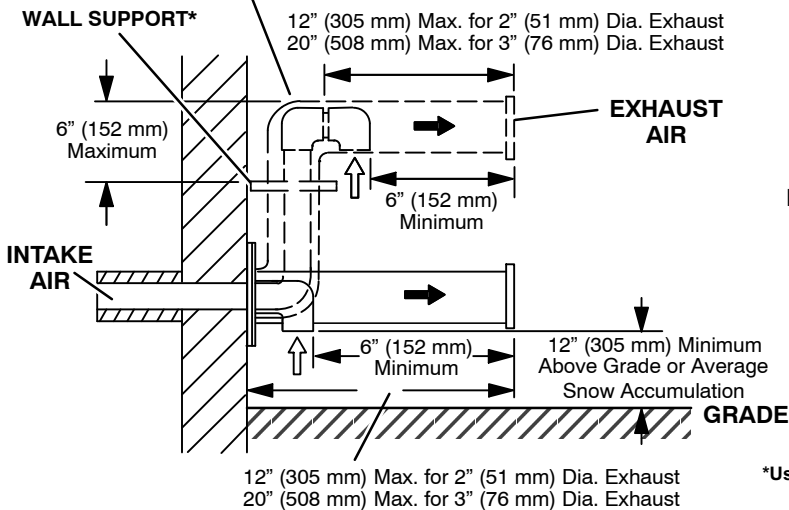
\*Use wall support every 24" (610). Use two supports if extension is greater than 24" but less than 48".

**FIGURE 32**

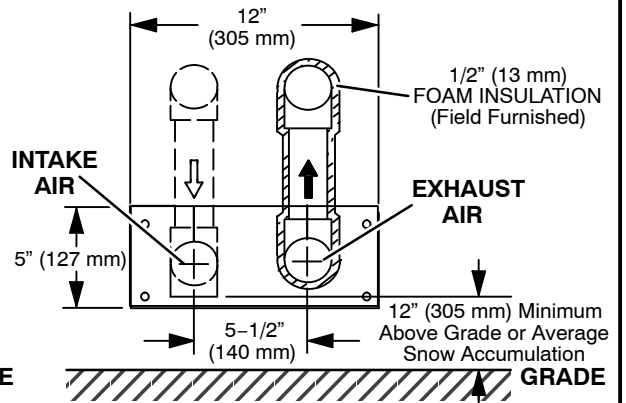
**WALL TERMINATION KITS (CLOSE-COUPLE)  
EXTENDED VENT FOR GRADE CLEARANCE  
2 inch (51 mm) 30G28 (WTK Canada)  
3 inch (76 mm) 81J20 (WTK Canada)**

**See Installation Instructions for additional information.**

If Intake and Exhaust Pipe is less than 12 in. (305 mm) above snow accumulation or other obstructions, field fabricated piping must be installed.

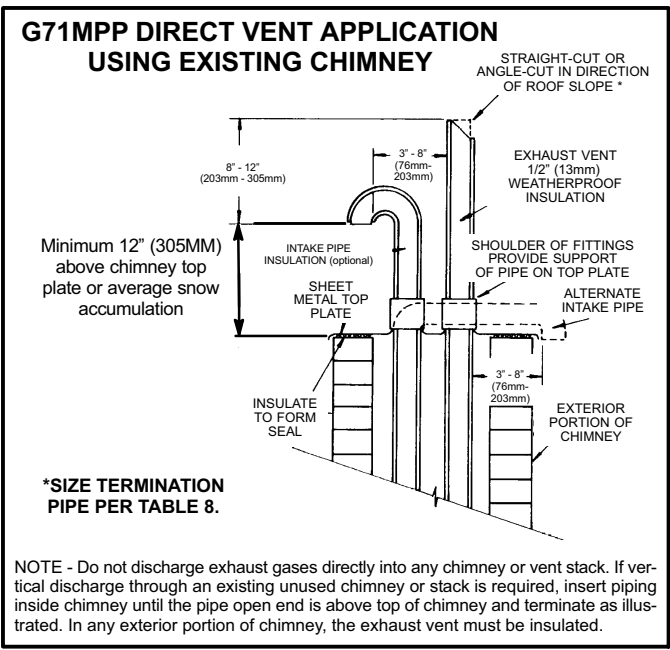


**FIELD-PROVIDED  
REDUCER MAY BE REQUIRED TO ADAPT  
LARGER VENT PIPE SIZE TO TERMINATION**



\*Use wall support every 24" (610). Use two supports if extension is greater than 24" but less than 48".

**FIGURE 33**

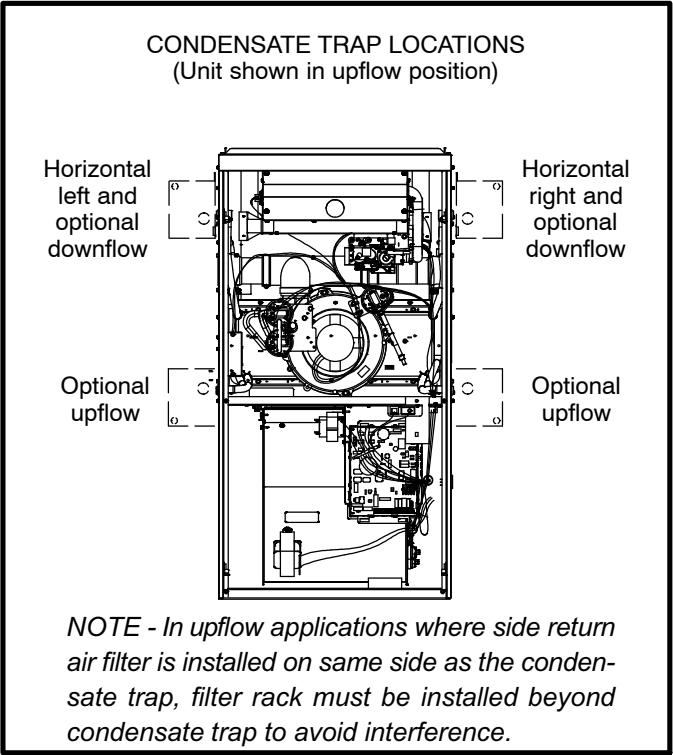


**FIGURE 34**

**Condensate Piping**

This unit is designed for either right- or left-side exit of condensate piping in either upflow or downflow applications; however, it must be installed on the same side of the unit as the exhaust piping. In horizontal applications, the condensate trap should extend below the unit. A 5-1/2" service clearance is required for the condensate trap. Refer to figure 35 for condensate trap locations.

**NOTE** - If necessary the condensate trap may be installed in an alternate location in upflow applications using kit number 76M20.



**FIGURE 35**

1 - Determine which side condensate piping will exit the unit. Remove plugs from the condensate collar at the appropriate location on the side of the unit.

**NOTE** - The condensate trap is factory-shipped with two rubber O-rings and two rubber clean-out caps installed. Check to make sure that these items are in place before installing the trap assembly.

2 - Install condensate trap onto the condensate collar. Use provided HI/LO screws to secure two upper flanges of the trap to the collar. Use provided sheet metal screw to secure bottom trap flange to side of unit. **DO NOT apply glue to secure condensate trap to cabinet.** All other joints must be glued. See figure 36.

**NOTE** - In upflow and downflow applications, condensate trap must be installed on the same side as exhaust piping.

**⚠ CAUTION**

**DO NOT use a power driver to tighten screws which secure condensate trap to cabinet. Screws should be hand-tightened using a screw driver to avoid the possibility of damage to the trap assembly.**

3 - The grey-colored condensate trap (101661-01) provided with the unit is manufactured using ABS material. This is the only trap that is to be used with this unit. Use ABS to PVC transition solvent cement to glue a field-provided PVC coupling or PVC pipe to the trap. Install a tee and vent pipe near the trap.

**NOTE** - The condensate trap drain stubs (both sides) have an outer diameter which will accept a standard 3/4" PVC coupling. The inner diameter of each stub will accept standard 1/2" diameter PVC pipe.

**NOTE** - Vinyl tubing may be used for condensate drain. Tubing must be 1-1/4" OD X 1" ID and should be attached to the drain stubs on the trap using a hose clamp.

- 4 - Glue the field-provided drain line to the tee. Route the drain line to an open drain. As an alternate, clear vinyl tubing may be used to drain condensate away from the trap. Secure the vinyl tubing to the drain stubs on the trap using a hose clamp. Do not overtighten the hose clamp.

Condensate line must be sloped downward away from condensate trap to drain. If drain level is above condensate trap, condensate pump must be used. Condensate drain line should be routed within the conditioned space to avoid freezing of condensate and blockage of drain line. If this is not possible, a heat cable kit may be used on the condensate trap and line. Heating cable kit is available from Lennox in various lengths; 6 ft. (1.8m) - kit no. 26K68; 24 ft. (7.3m) - kit no. 26K69; and 50 ft. (15.2m) - kit no. 26K70.

 <b>CAUTION</b>
<b>Do not use copper tubing or existing copper condensate lines for drain line.</b>

- 5 - If unit will be started immediately upon completion of installation, prime trap per procedure outlined in Unit Start-Up section.
- 6 - Glue the provided cap onto the unused condensate drain line stub.

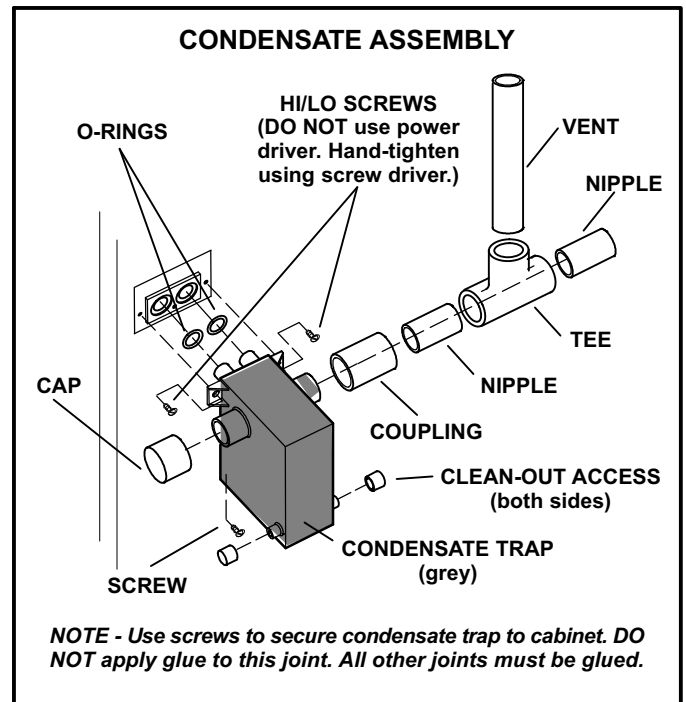


FIGURE 36

## Gas Piping

### ⚠ CAUTION

If a flexible gas connector is required or allowed by the authority that has jurisdiction, black iron pipe shall be installed at the gas valve and extend outside the furnace cabinet.

### ⚠ WARNING

Do not exceed 600 in.-lbs (50 ft.-lbs) torque when attaching the gas piping to the gas valve.

- 1 - Gas piping may be routed into the unit through either the left- or right-hand side. Supply piping enters into the gas valve from the side of the valve as shown in figures 38 and 39.
- 2 - When connecting gas supply, factors such as length of run, number of fittings and furnace rating must be considered to avoid excessive pressure drop. Table 9 lists recommended pipe sizes for typical applications.  
**NOTE** - Use two wrenches when connecting gas piping to avoid transferring torque to the manifold.
- 3 - Gas piping must not run in or through air ducts, clothes chutes, chimneys or gas vents, dumb waiters or elevator shafts. Center gas line through piping hole. Gas line should not touch side of unit. See figures 38 and 39.
- 4 - Piping should be sloped 1/4 inch per 15 feet (6mm per 5.6m) upward toward the gas meter from the furnace. The piping must be supported at proper intervals, every 8 to 10 feet (2.44 to 3.05m), using suitable hangers or straps. Install a drip leg in vertical pipe runs to serve as a trap for sediment or condensate.
- 5 - A 1/8" N.P.T. plugged tap or pressure post is located on the gas valve to facilitate test gauge connection. See figures 48.
- 6 - In some localities, codes may require installation of a manual main shut-off valve and union (furnished by installer) external to the unit. Union must be of the ground joint type.

### ⚠ IMPORTANT

Compounds used on threaded joints of gas piping must be resistant to the actions of liquified petroleum gases.

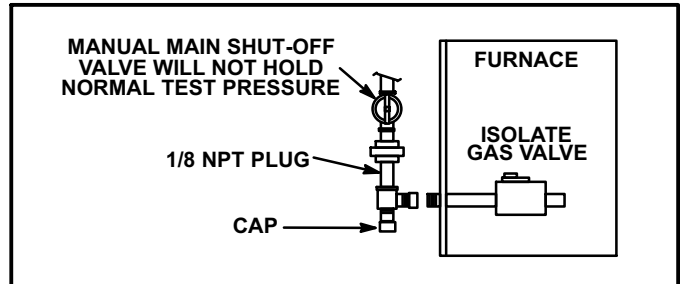


FIGURE 37

#### Leak Check

After gas piping is completed, carefully check all piping connections (factory- and field-installed) for gas leaks. Use a leak detecting solution or other preferred means.

*The furnace must be isolated from the gas supply system by closing its individual manual shut-off valve during any pressure testing of the gas supply system at pressures less than or equal to 1/2 psig (3.48 kPa, 14 inches w.c.).*

### ⚠ IMPORTANT

When testing gas lines using pressures in excess of 1/2 psig (3.48 kPa), gas valve must be disconnected and isolated. See figure 37. Gas valves can be damaged if subjected to pressures greater than 1/2 psig (3.48 kPa).

### ⚠ WARNING

#### FIRE OR EXPLOSION HAZARD

Failure to follow the safety warnings exactly could result in serious injury, death, or property damage. Never use an open flame to test for gas leaks. Check all connections using a commercially available soap solution made specifically for leak detection. Some soaps used for leak detection are corrosive to certain metals. Carefully rinse piping thoroughly after leak test has been completed.

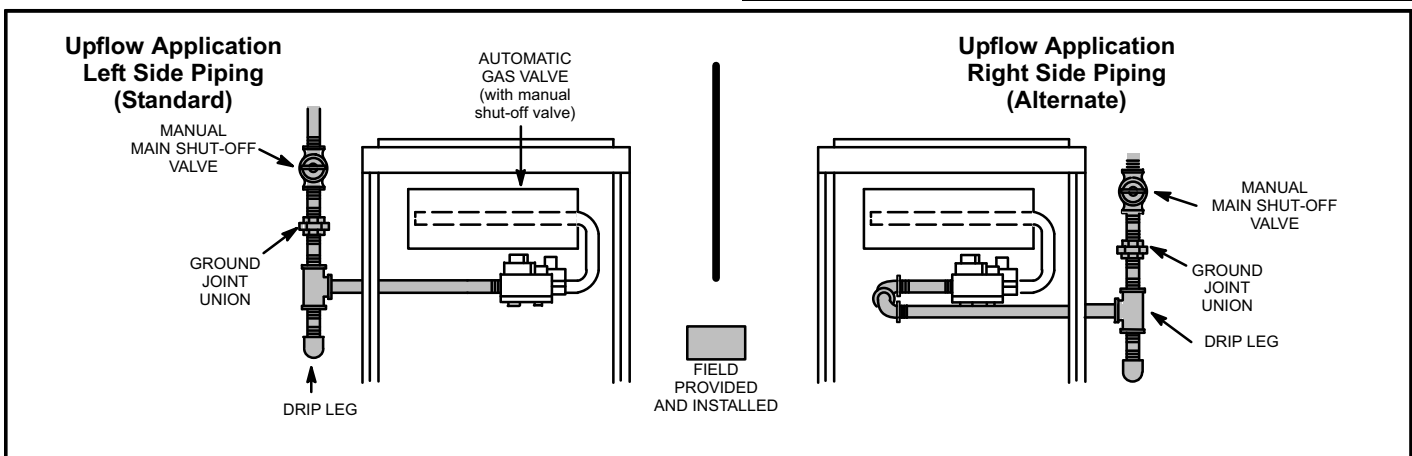
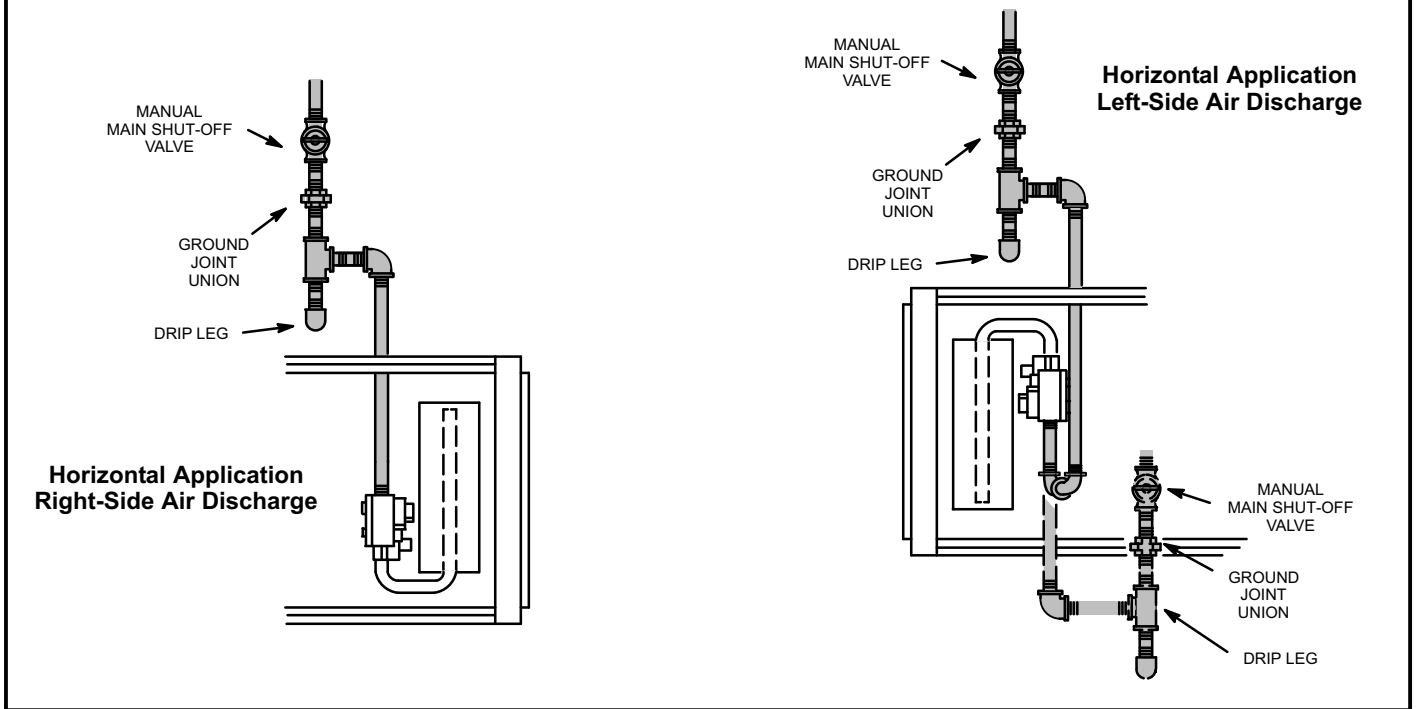


Figure 38

**Horizontal Applications  
Possible Gas Piping Configurations**



**FIGURE 39**

**TABLE 9  
GAS PIPE CAPACITY - FT<sup>3</sup>/HR (kL/HR)**

Nominal Iron Pipe Size -Inches(mm)	Internal Diameter -Inches(mm)	Length of Pipe-Feet(m)									
		10 (3.048)	20 (6.096)	30 (9.144)	40 (12.192)	50 (15.240)	60 (18.288)	70 (21.336)	80 (24.384)	90 (27.432)	100 (30.480)
1/4 (6.35)	.364 (9.246)	43 (1.13)	29 (.82)	24 (.68)	20 (.57)	18 (.51)	16 (.45)	15 (.42)	14 (.40)	13 (.37)	12 (.34)
3/8 (9.53)	.493 (12.522)	95 (2.69)	65 (1.84)	52 (1.47)	45 (1.27)	40 (1.13)	36 (1.02)	33 (.73)	31 (.88)	29 (.82)	27 (.76)
1/2 (12.7)	.622 (17.799)	175 (4.96)	120 (3.40)	97 (2.75)	82 (2.32)	73 (2.07)	66 (1.87)	61 (1.73)	57 (1.61)	53 (1.50)	50 (1.42)
3/4 (19.05)	.824 (20.930)	360 (10.19)	250 (7.08)	200 (5.66)	170 (4.81)	151 (4.28)	138 (3.91)	125 (3.54)	118 (3.34)	110 (3.11)	103 (2.92)
1 (25.4)	1.049 (26.645)	680 (19.25)	465 (13.17)	375 (10.62)	320 (9.06)	285 (8.07)	260 (7.36)	240 (6.80)	220 (6.23)	205 (5.80)	195 (5.52)
1-1/4 (31.75)	1.380 (35.052)	1400 (39.64)	950 (26.90)	770 (21.80)	660 (18.69)	580 (16.42)	530 (15.01)	490 (13.87)	460 (13.03)	430 (12.18)	400 (11.33)
1-1/2 (38.1)	1.610 (40.894)	2100 (59.46)	1460 (41.34)	1180 (33.41)	990 (28.03)	900 (25.48)	810 (22.94)	750 (21.24)	690 (19.54)	650 (18.41)	620 (17.56)
2 (50.8)	2.067 (52.502)	3950 (111.85)	2750 (77.87)	2200 (62.30)	1900 (53.80)	1680 (47.57)	1520 (43.04)	1400 (39.64)	1300 (36.81)	1220 (34.55)	1150 (32.56)
2-1/2 (63.5)	2.469 (67.713)	6300 (178.39)	4350 (123.17)	3520 (99.67)	3000 (84.95)	2650 (75.04)	2400 (67.96)	2250 (63.71)	2050 (58.05)	1950 (55.22)	1850 (52.38)
3 (76.2)	3.068 (77.927)	11000 (311.48)	7700 (218.03)	6250 (176.98)	5300 (150.07)	4750 (134.50)	4300 (121.76)	3900 (110.43)	3700 (104.77)	3450 (97.69)	3250 (92.03)
4 (101.6)	4.026 (102.260)	23000 (651.27)	15800 (447.39)	12800 (362.44)	10900 (308.64)	9700 (274.67)	8800 (249.18)	8100 (229.36)	7500 (212.37)	7200 (203.88)	6700 (189.72)

NOTE - Capacity given in cubic feet of gas per hour (kilo liters of gas per hour) and based on 0.60 specific gravity gas.

## Electrical

### ELECTROSTATIC DISCHARGE (ESD)

#### Precautions and Procedures

## ⚠ CAUTION

Electrostatic discharge can affect electronic components. Take precautions during furnace installation and service to protect the furnace's electronic controls. Precautions will help to avoid control exposure to electrostatic discharge by putting the furnace, the control and the technician at the same electrostatic potential. Neutralize electrostatic charge by touching hand and all tools on an unpainted unit surface, such as the gas valve or blower deck, before performing any service procedure.

The unit is equipped with a field make-up box. The make-up box may be moved to the right side of the furnace to facilitate installation. If the make-up box is moved to the right side, the excess wire must be pulled into the blower compartment. Secure the excess wire to the existing harness to protect it from damage.

Refer to figure 42 for unit field wiring. See figures 43 and 44 for icomfort Touch™ thermostat wiring in communicating applications. Table 10 shows DIP switch and on-board link settings for non-communicating thermostat applications. Typical wiring schematic is shown in figure 45.

- 1 - The power supply wiring must meet Class I restrictions. Protected by either a fuse or circuit breaker, select circuit protection and wire size according to unit nameplate.

**NOTE** - Unit nameplate states maximum current draw. Maximum Over-Current Protection allowed is 20AMP.

- 2 - Holes are on both sides of the furnace cabinet to facilitate wiring.
- 3 - Install a separate (properly sized) disconnect switch near the furnace so that power can be turned off for servicing.
- 4 - Before connecting the thermostat or the power wiring, check to make sure the wires will be long enough for servicing at a later date. Remove the blower access panel to check the length of the wire.
- 5 - Complete the wiring connections to the equipment. Use the provided unit wiring diagram and the field wiring diagram shown in figure 42 and table 10. Use 18-gauge wire or larger that is suitable for Class II rating for thermostat connections.

**NOTE** - Do NOT make a wire connection between the room thermostat L terminal and the L terminal of the G71MPP integrated control unless this is a communicating thermostat installation with a non-communicating outdoor unit.

- 6 - Electrically ground the unit according to local codes or, in the absence of local codes, according to the current National Electric Code (ANSI/NFPA No. 70) for the USA and current Canadian Electric Code part 1 (CSA standard C22.1) for Canada. A green ground wire is provided in the field make-up box.
- 7 - One line voltage "EAC" 1/4" spade terminal is provided on the furnace integrated control. Any electronic air cleaner rated up to one amp can be connected to this terminal with the neutral leg of the circuit being connected to one of the provided neutral terminals. See figure 46 for integrated control configuration. This terminal is energized when the indoor blower is operating.
- 8 - One line voltage "HUM" 1/4" spade terminal is provided on the furnace integrated control. Any humidifier rated up to one amp can be connected to this terminal with the neutral leg of the circuit being connected to one of

#### INTERIOR MAKE-UP BOX INSTALLATION

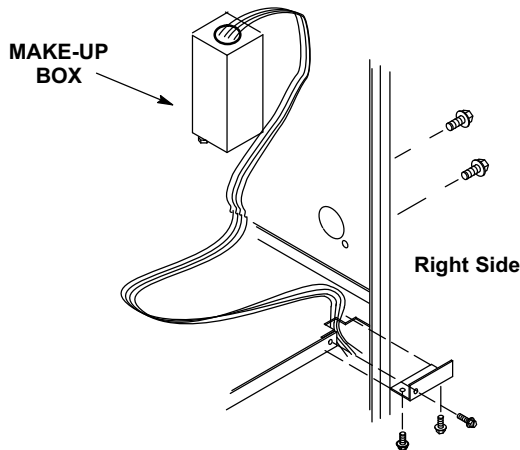


FIGURE 40

#### INTERIOR MAKE-UP BOX INSTALLATION

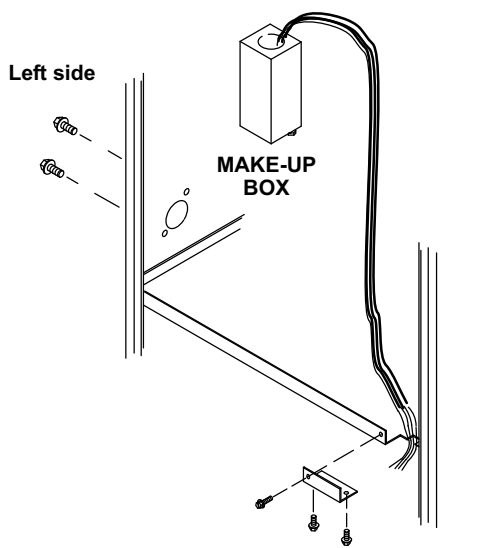


FIGURE 41

the provided neutral terminals. See figure 46 for integrated control configuration. This terminal is energized in the heating mode when the combustion air inducer is operating.

- 9 - One 24V "H" terminal is provided on the furnace integrated control terminal block. Any humidifier rated up to 0.5 amp can be connected to this terminal with the ground leg of the circuit being connected to either ground or the "C" terminal. See figure 46 for integrated control configuration.

- 10 - Install the room thermostat according to the instructions provided with the thermostat. See table 10 for thermostat connections. If the furnace is being matched with a heat pump, refer to the instruction packaged with the dual fuel thermostat.

**NOTE** - The discharge air temperature sensor is intended to be mounted downstream of the heat exchanger and air conditioning coil. It must be placed in free airflow, where other accessories (humidifiers, UV lights etc.) will not interfere with its accuracy. Wiring distance between the furnace and discharge air sensor should not exceed 10 ft. when wired with 18-gauge thermostat wire.

**NOTE** - Wiring distance between the furnace and the outdoor air sensor should not exceed 200ft. when wired with 18-gauge thermostat wire.

**NOTE** - Maximum total length of all connections on the RSBus is limited to 1500ft

**Thermostat Selection**

The G71MPP is designed to operate in a variable rate ca-

capacity mode using a two-stage thermostat. The G71MPP will automatically adjust firing rate based upon thermostat cycle times.

The icomfort Touch™ thermostat must be used in communicating applications. Refer to the illustrations provided with the thermostat for installation, set-up and operation.

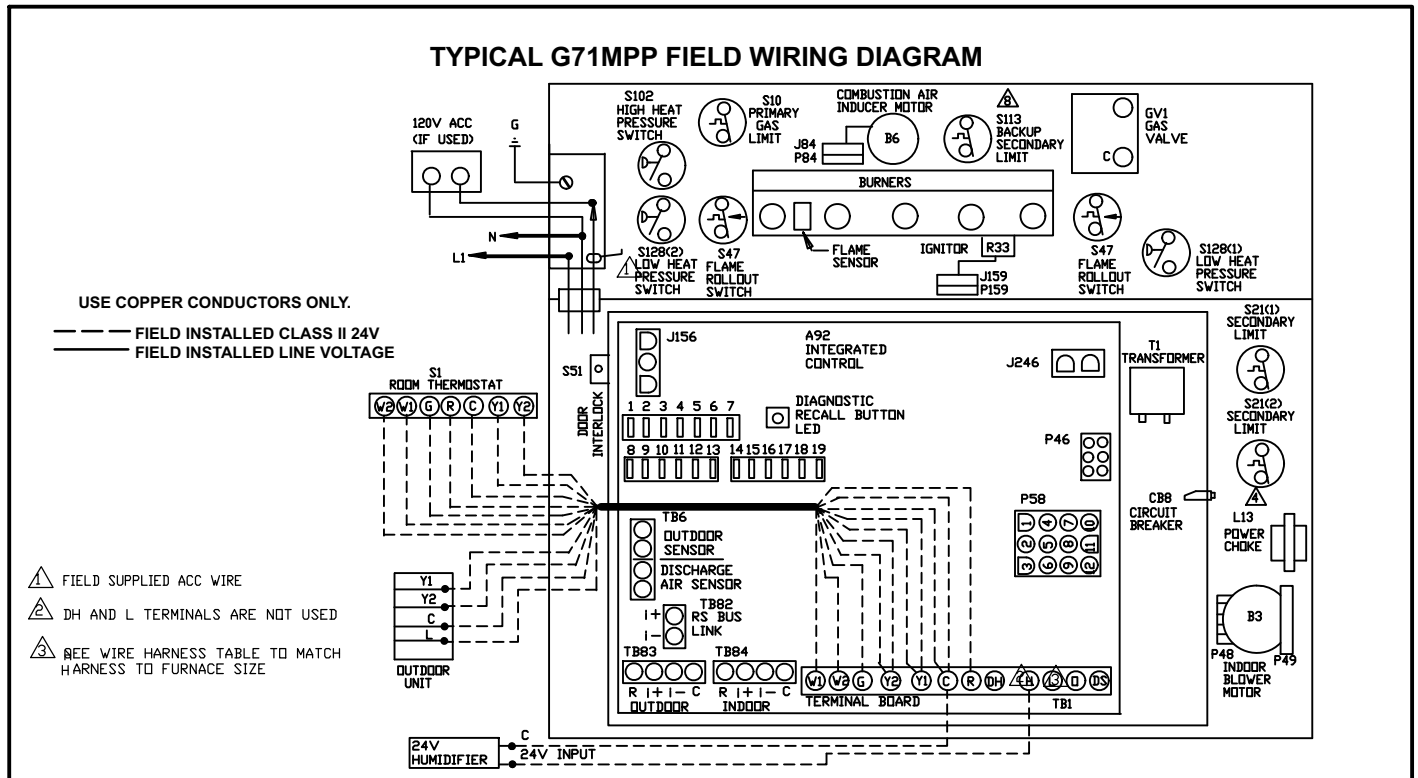
For optimal performance in non-communicating applications, Lennox recommends use of a high quality electronic digital thermostat with adjustable settings for 1st stage / 2nd stage on / off differentials and adjustable stage timers.

Lennox recommends the following two-stage thermostat set-up for optimal variable rate capacity mode:

First heat stage differential set to 1/2 to 1 degree F; second heat stage differential set to 1/2 or 1 degree F; second heat stage upstage timer disabled, or set to maximum (1 hr minimum).

**Indoor Blower Speeds**

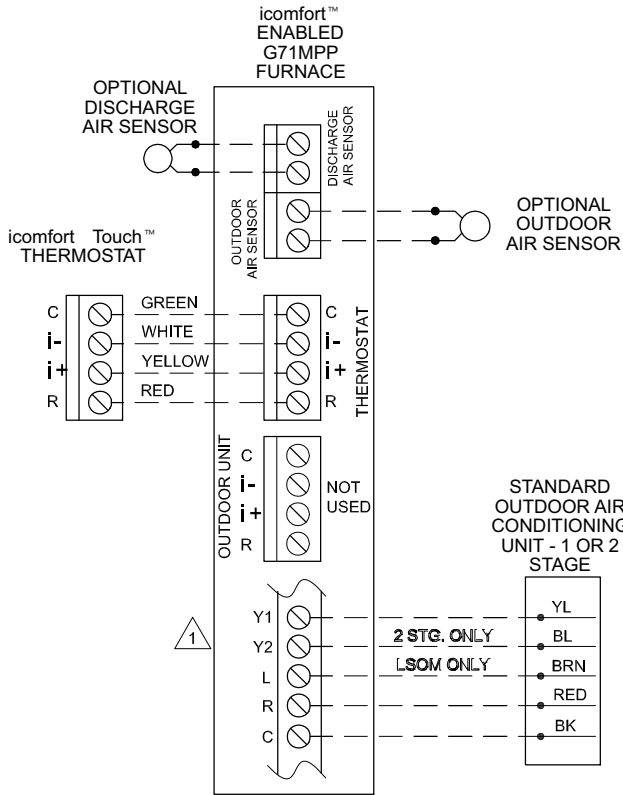
- 1 - When the thermostat is set to "FAN ON," the indoor blower will run continuously at a percentage of the second-stage cooling speed when there is no cooling or heating demand. The percentage is set using DIP switches 6 and 7.
- 2 - When the G71MPP is running in the heating mode, the integrated control will automatically adjust the blower speed to match the furnace firing rate. This speed can be adjusted up or down by 7.5% or 15% using DIP switches 14 through 16 for the low heat speed and 17 through 19 for the high heat speed.
- 3 - When there is a cooling demand, the indoor blower will run on the cooling speed designated by the positions of DIP switches 8 through 11.



**FIGURE 42**

**icomfort Touch™ Communicating Unit  
non-Communicating Outdoor Unit**

icomfort Touch™ Thermostat  
icomfort™ Enabled G71MPP Indoor Furnace  
Standard Outdoor Air Conditioner



**icomfort Touch™ Communicating Systems**

icomfort Touch™ Thermostat  
icomfort™ Enabled G71MPP Indoor Furnace  
icomfort™ Outdoor Air Conditioner or Heat Pump

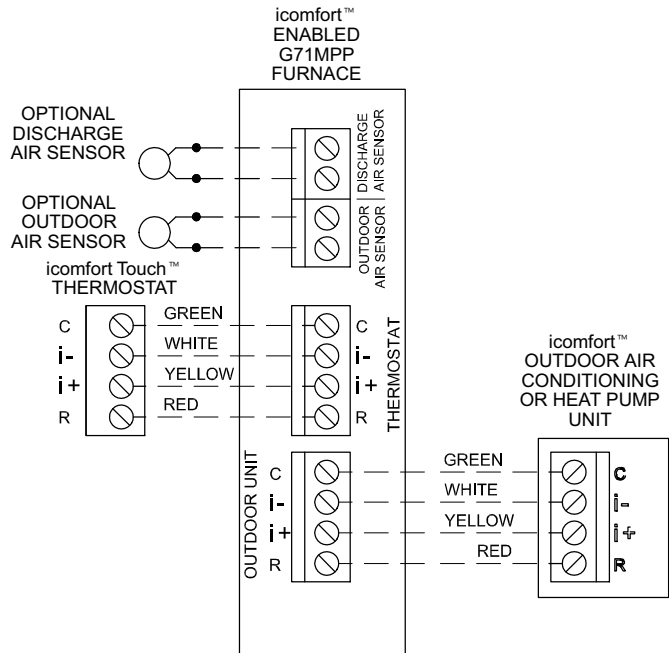
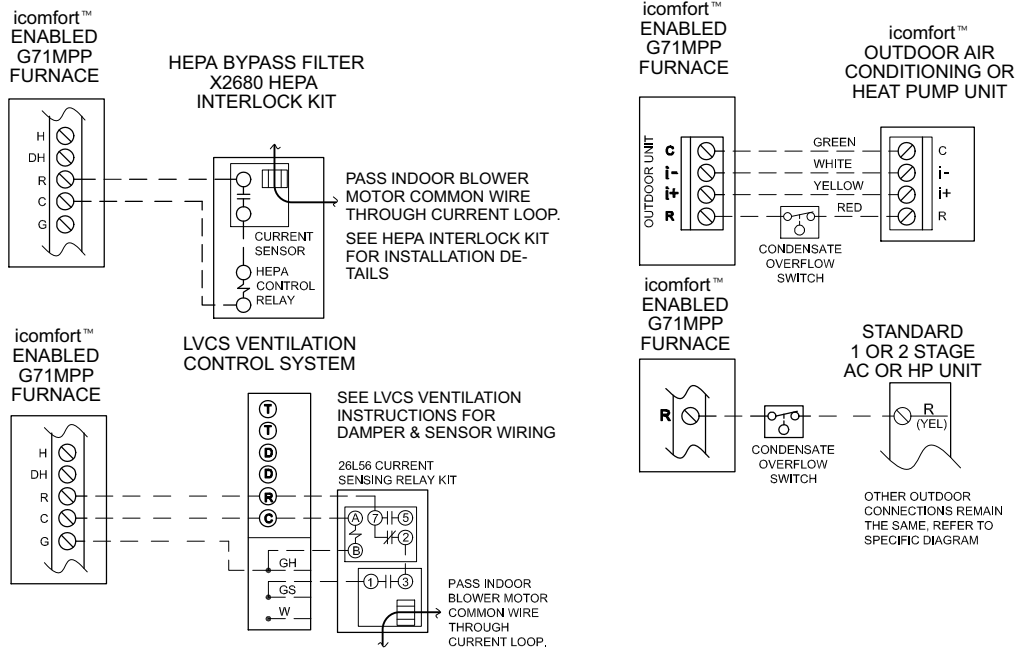
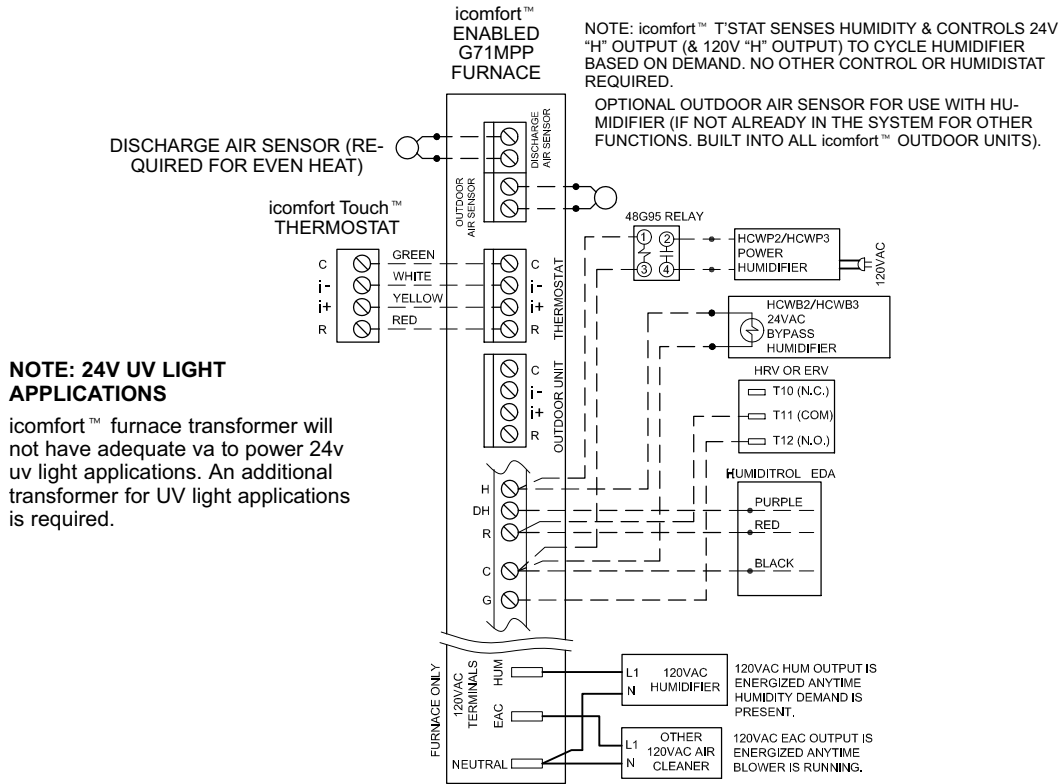


FIGURE 43



## Optional Accessories for use with any icomfort™ System



**FIGURE 44**

**TABLE 10**  
**Field Wiring for Non-Communicating Thermostat Applications**

Thermostat	DIP Switch Settings and On-Board Links (figure 46)				Wiring Connections
	DIP Switch 1	W915 (Y1 to Y2) Two-Stage Cooling	W914 (DS to R) Dehumidifi- cation or Harmony III™	W951 (O to R) Heat Pumps	
1Heat / 1 Cool <i>NOTE - Use DIP switch 3 to set second-stage heat ON delay. OFF-7 minutes. ON-12 minutes.</i>	ON	Intact	Intact	Intact	
1 Heat / 2 Cool <i>NOTE - Use DIP switch 3 to set second-stage heat ON delay. OFF-7 minutes. ON-12 minutes.</i>	ON	Cut	Intact	Intact	
1 Heat / 2 Cool with t'stat with dehumidification mode <i>NOTE - Use DIP switch 3 to set second-stage heat ON delay. OFF-7 minutes. ON-12 minutes.</i>	ON	Cut	Cut	Intact	

\* "R" required on some units.

**TABLE 10**  
**Field Wiring for Non-Communicating Thermostat Applications (Continued)**

Thermostat	DIP Switch Settings and On-Board Links (figure 46)				Wiring Connections																														
	DIP Switch 1	W915 (Y1 to Y2) Two-Stage Cooling	W914 (DS to R) Dehumidifi- cation or Harmony III™	W951 (O to R) Heat Pumps																															
2 Heat / 2 Cool	OFF	Cut	Intact	Intact	<table border="0"> <tr> <td>S1 T'STAT</td> <td>CONTROL TERM. STRIP</td> <td>OUTDOOR UNIT</td> </tr> <tr> <td></td> <td align="center">DS</td> <td></td> </tr> <tr> <td>W2</td> <td>W2</td> <td></td> </tr> <tr> <td>W1</td> <td>W1</td> <td></td> </tr> <tr> <td>R</td> <td>R</td> <td>* R</td> </tr> <tr> <td>G</td> <td>G</td> <td></td> </tr> <tr> <td>C</td> <td>C</td> <td>C</td> </tr> <tr> <td>Y2</td> <td>Y2</td> <td>Y2</td> </tr> <tr> <td>Y1</td> <td>Y1</td> <td>Y1</td> </tr> <tr> <td></td> <td align="center">O</td> <td></td> </tr> </table>	S1 T'STAT	CONTROL TERM. STRIP	OUTDOOR UNIT		DS		W2	W2		W1	W1		R	R	* R	G	G		C	C	C	Y2	Y2	Y2	Y1	Y1	Y1		O	
S1 T'STAT	CONTROL TERM. STRIP	OUTDOOR UNIT																																	
	DS																																		
W2	W2																																		
W1	W1																																		
R	R	* R																																	
G	G																																		
C	C	C																																	
Y2	Y2	Y2																																	
Y1	Y1	Y1																																	
	O																																		
2 Heat / 2 Cool with t'stat with dehumidifica- tion mode	OFF	Cut	Cut	Intact	<table border="0"> <tr> <td>S1 T'STAT</td> <td>CONTROL TERM. STRIP</td> <td>OUTDOOR UNIT</td> </tr> <tr> <td>D</td> <td>DS</td> <td></td> </tr> <tr> <td>W2</td> <td>W2</td> <td></td> </tr> <tr> <td>W1</td> <td>W1</td> <td></td> </tr> <tr> <td>R</td> <td>R</td> <td>* R</td> </tr> <tr> <td>G</td> <td>G</td> <td></td> </tr> <tr> <td>C</td> <td>C</td> <td>C</td> </tr> <tr> <td>Y2</td> <td>Y2</td> <td>Y2</td> </tr> <tr> <td>Y1</td> <td>Y1</td> <td>Y1</td> </tr> </table>	S1 T'STAT	CONTROL TERM. STRIP	OUTDOOR UNIT	D	DS		W2	W2		W1	W1		R	R	* R	G	G		C	C	C	Y2	Y2	Y2	Y1	Y1	Y1			
S1 T'STAT	CONTROL TERM. STRIP	OUTDOOR UNIT																																	
D	DS																																		
W2	W2																																		
W1	W1																																		
R	R	* R																																	
G	G																																		
C	C	C																																	
Y2	Y2	Y2																																	
Y1	Y1	Y1																																	
2 Heat / 1 Cool	OFF	Intact	Intact	Intact	<table border="0"> <tr> <td>S1 T'STAT</td> <td>CONTROL TERM. STRIP</td> <td>OUTDOOR UNIT</td> </tr> <tr> <td></td> <td align="center">DS</td> <td></td> </tr> <tr> <td>W2</td> <td>W2</td> <td></td> </tr> <tr> <td>W1</td> <td>W1</td> <td></td> </tr> <tr> <td>R</td> <td>R</td> <td>* R</td> </tr> <tr> <td>G</td> <td>G</td> <td></td> </tr> <tr> <td>C</td> <td>C</td> <td>C</td> </tr> <tr> <td></td> <td align="center">Y2</td> <td></td> </tr> <tr> <td>Y</td> <td>Y1</td> <td>Y1</td> </tr> <tr> <td></td> <td align="center">O</td> <td></td> </tr> </table>	S1 T'STAT	CONTROL TERM. STRIP	OUTDOOR UNIT		DS		W2	W2		W1	W1		R	R	* R	G	G		C	C	C		Y2		Y	Y1	Y1		O	
S1 T'STAT	CONTROL TERM. STRIP	OUTDOOR UNIT																																	
	DS																																		
W2	W2																																		
W1	W1																																		
R	R	* R																																	
G	G																																		
C	C	C																																	
	Y2																																		
Y	Y1	Y1																																	
	O																																		

\* "R" required on some units.

**TABLE 10**  
**Field Wiring for Non-Communicating Thermostat Application (Continued)**

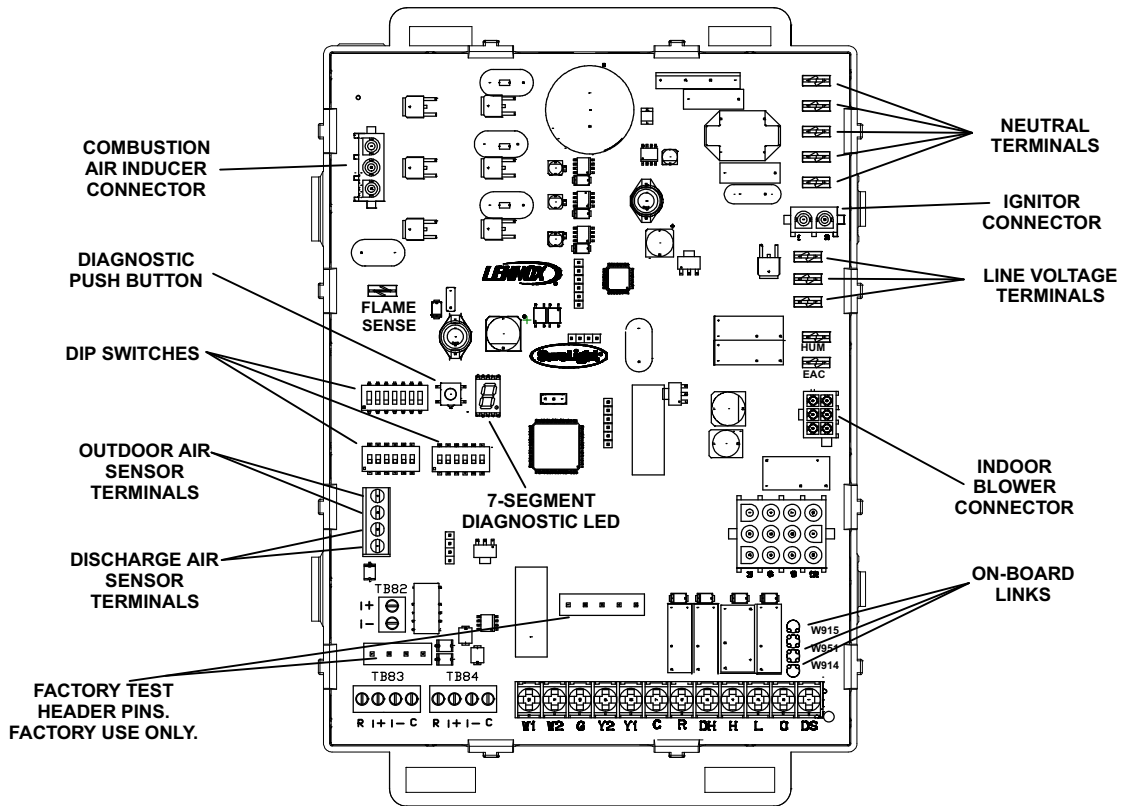
Thermostat	DIP Switch Settings and On-Board Links (figure 46)			Wiring Connections	
	DIP Switch	W915 (Y1 to Y2) Two-Stage Cooling	W914 (DS to R) Dehumidifi- cation or Harmony III™		W951 (O to R) Heat Pumps
Dual Fuel Single Stage Heat Pump  ComfortSense 7000 L7724U thermostat w/ dual fuel capa- bilities Capable of 2 stage gas heat control	DIP Switch 1 OFF	Intact	Intact	Cut	
Dual Fuel Two Stage Heat Pump  ComfortSense 7000 L7724U thermostat w/ dual fuel capa- bilities Capable of 2 stage gas heat control	DIP Switch 1 OFF	Cut	Intact	Cut	

\* Connect W1 to W1 ONLY if using defrost tempering kit 67M41

NOTE - Do NOT make a wire connection between the room thermostat L terminal and the L terminal of the G71MPP integrated control.



**INTEGRATED CONTROL**



**RS-BUS LINK (TB82, future use)**

I+ = DATA HIGH CONNECTION  
I- = DATA LOW CONNECTION

**RS-BUS OUTDOOR (TB83)**

R = 24VAC  
I+ = DATA HIGH CONNECTION  
I- = DATA LOW CONNECTION  
C = 24VAXC COMMON

**RS-BUS OUTDOOR (TB84)**

R = 24VAC  
I+ = DATA HIGH CONNECTION  
I- = DATA LOW CONNECTION  
C = 24VAXC COMMON

**THERMOSTAT CONNECTIONS (TB1)**

DS= DEHUMIDIFICATION SIGNAL  
W2= HEAT DEMAND FROM 2ND STAGE T'STAT  
W1= HEAT DEMAND FROM 1ST STAGE T'STAT  
R= CLASS 2 VOLTAGE TO THERMOSTAT  
G= MANUAL FAN FROM T'STAT  
C= THERMOSTAT SIGNAL GROUND CONNECTED TO TRANSFORMER GROUND (TR) & CHASIS GROUND (GRD)  
Y1= THERMOSTAT 1st STAGE COOL SIGNAL  
Y2= THERMOSTAT 2nd STAGE COOL SIGNAL  
O= THERMOSTAT SIGNAL TO HEAT PUMP REVERSING VALVE  
H= 24V HUMIDIFIER OUTPUT  
L= USE ONLY WITH A COMMUNICATING THERMOSTAT AND A NON-COMMUNICATING OUTDOOR UNIT

**1/4" QUICK CONNECT TERMINALS**

HUM = 120 VAC OUTPUT TO HUMIDIFIER  
XMFR = 120 VAC OUTPUT TO TRANSFORMER  
LI = 120 VAC INPUT TO CONTROL  
CIRC = 120 VAC OUTPUT TO CIRCULATING BLOWER  
EAC = 120 VAC OUTPUT TO ELECTRONIC AIR CLEANER  
NEUTRALS= 120 VAC NEUTRAL

**FIGURE 46**

**TABLE 11  
Thermostat Selection Switch Settings**

Operation	Thermostat	Switch 1	Switch 2	Switch 3
Variable Capacity Heat (40% to 100%)	Two-Stage	Off	On	Off
Three-Stage Heat (40%, 70%, 100%)	Single-Stage	On	Off	2nd stage delay OFF = 7 minutes ON = 12 minutes 3rd stage delay 10 minutes fixed
Two-Stage Heat (W1 70%, W2 100%)	Two-Stage	Off	Off	Off

G71MPP units are equipped with a variable-capacity, variable-speed integrated control. This control manages ignition timing, combustion air inducer speed, heating mode fan off delays and indoor blower speeds based on selections made using the control DIP switches and on-board links. The control includes an internal watchdog feature which automatically resets the ignition control when it has been locked out.

**Heating Operation DIP Switch Settings -- Figure 46**

**Switch 1 -- Thermostat Selection --** This unit may be used with either a single-stage or two-stage thermostat. The thermostat selection is made using a DIP switch which must be properly positioned for the particular application. The DIP switch is factory-positioned for use with a two-stage thermostat. If a single-stage thermostat is to be used, the DIP switch must be repositioned. See table 11.

**Switch 2 -- Operating Mode with Two-Stage Thermostat --** If a two-stage thermostat is used, the furnace can operate in either variable-capacity or conventional two-stage mode. When variable-capacity mode is selected, the firing rate of the unit is varied to maximize comfort. Conventional two-stage mode is the factory default setting. See table 11.

**Switch 3 -- Second-Stage Heat On Delay --** If a single-stage thermostat is used, the integrated control can be used to energize second-stage heat after either 7 minutes or 12 minutes of first-stage heat operation. See table 11.

**Switches 4 and 5 -- Blower-Off Delay --** The blower-off delay of 45 seconds is not adjustable. The blower-off delay (time that the blower operates after the heating demand has been satisfied) can be adjusted by moving switches 4 and 5 on the integrated control. The unit is shipped from the factory with a blower-off delay of 90 seconds. The blower

off delay affects comfort and is adjustable to satisfy individual applications. Adjust the blower off delay to achieve a supply air temperature between 90° and 110°F at the exact moment that the blower is de-energized. Longer off delay settings provide lower supply air temperatures; shorter settings provide higher supply air temperatures. Table 12 provides the blower off timings that will result from different switch settings.

**TABLE 12  
Blower Off Delay Switch Settings**

Blower Off Delay (Seconds)	Switch 4	Switch 5
60	Off	On
90	Off	Off
120	On	Off
180	On	On

**Indoor Blower Operation DIP Switch Settings**

**Switches 6 and 7 -- Continuous Indoor Fan Operation-Blower Speed --** Switches 6 and 7 are used to select blower motor speeds during continuous indoor blower operation. The unit is shipped from the factory with the DIP switches positioned for medium low (2) speed during continuous indoor blower operation. The table below provides the continuous blower speeds that will result from different switch settings. Refer to tables 21 through 31 for corresponding cfm values.

**TABLE 13  
Continuous Indoor Blower Operation -- Blower Speeds**

Speed	Switch 6	Switch 7
1 - Low	Off	On
2 - Medium Low (Factory)	Off	Off
3 - Medium High	On	Off
4 - High	On	On

**Switches 8 and 9 -- Cooling Mode Blower Speed --**

Switches 8 and 9 are used to select cooling blower motor speed. The unit is shipped from the factory with the DIP switches positioned for high speed (4) indoor blower motor operation during the cooling mode. The table below provides the cooling mode blower speeds that will result from different switch settings. Refer to tables 21 through 31 for corresponding cfm values.

**TABLE 14  
Cooling Mode Blower Speeds**

Speed	Switch 8	Switch 9
1 - Low	On	On
2 - Medium Low	Off	On
3 - Medium High	On	Off
4 - High (Factory)	Off	Off

**Switches 10 and 11 -- Cooling Mode Blower Speed Adjustment --**

Switches 10 and 11 are used to select blower speed adjustment settings. The unit is shipped from the factory with the DIP switches positioned for NORMAL (no) adjustment. The DIP switches may be positioned to adjust the blower speed by +10% or -10% to better suit the application. Table 15 provides blower speed adjustments that will result from different switch settings. Refer to tables 21 through 31 for corresponding cfm values.

With switches 10 and 11 set to ON, motor will bypass ramping profiles and all delays and will immediately run at selected COOLING speed upon a call for cool. LED will continue to operate as normal. This mode is used to check motor operation.

**TABLE 15  
Cooling Mode Blower Speed Adjustment**

Adjustment	Switch 10	Switch 11
+10% (approx.)	On	Off
NORMAL (Factory)	Off	Off
-10% (approx.)	Off	On
MOTOR TEST	On	On

**Switches 12 and 13 -- Cooling Mode Blower Speed Ramping --**

Switches 12 and 13 are used to select cooling mode blower speed ramping options. Blower speed ramping may be used to enhance dehumidification performance. The switches are factory set at option A which has the greatest effect on blower motor performance. Table 16 provides the cooling mode blower speed ramping options that will result from different switch settings. The cooling mode blower speed ramping options are detailed below.

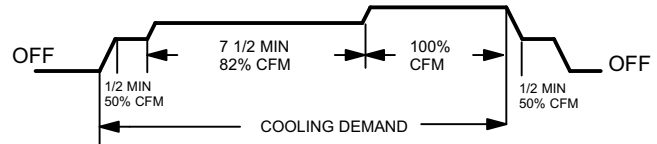
**NOTE** - The off portion of the selected ramp profile only applies during heat pump operation in dual fuel applications.

**TABLE 16  
Cooling Mode Blower Speed Ramping**

Ramping Option	Switch 12	Switch 13
A (Factory)	Off	Off
B	On	Off
C	Off	On
D	On	On

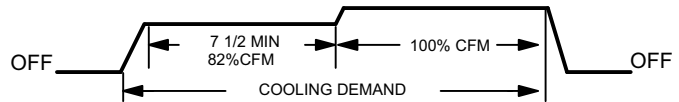
**Ramping Option A (Factory Selection)**

- Motor runs at 50% for 30 seconds.
- Motor then runs at 82% for approximately 7-1/2 minutes.
- If demand has not been satisfied after 7-1/2 minutes, motor runs at 100% until demand is satisfied.
- Once demand is met, motor runs at 50% for 30 seconds then ramps down to stop.



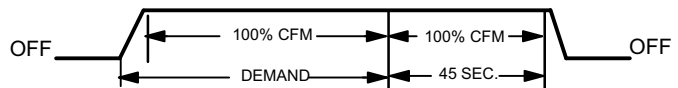
**Ramping Option B**

- Motor runs at 82% for approximately 7-1/2 minutes. If demand has not been satisfied after 7-1/2 minutes, motor runs at 100% until demand is satisfied.
- Once demand is met, motor ramps down to stop.



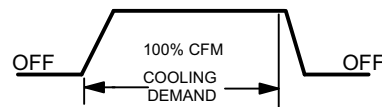
**Ramping Option C**

- Motor runs at 100% until demand is satisfied.
- Once demand is met, motor runs at 100% for 45 seconds then ramps down to stop.



**Ramping Option D**

- Motor runs at 100% until demand is satisfied.
- Once demand is met, motor ramps down to stop.





**Switches 14 through 19 -- Heating Mode Blower Speed**

-- Switches 14 through 19 are used to select heating mode blower motor speeds. These switches are factory set at the OFF position which provides 100 % of normal speed during HIGH HEAT demand, 70% of normal speed during MID-RANGE HEAT demand and 40% of normal speed during LOW HEAT demand. Switches 14, 15 and 16 are used to adjust the LOW HEAT blower motor speed. Switches 17, 18 and 19 are used to adjust the HIGH HEAT blower motor speed. Table 17 provides the heating mode blower speeds that will result from different switch settings. Refer to tables 21 through 31 for corresponding cfm values.

**TABLE 17  
Low Heat Blower Speeds**

Thermostat Demand	Blower Speed Adjustments	DIP SWITCH SETTINGS		
		14	15	16
Low Heat (R to W1)	+15%	On	Off	On
	+7.5%	On	Off	Off
	Normal	Off	Off	Off
	-7.5%	On	On	Off
	-15%	On	On	On

**TABLE 18  
High Heat Blower Speeds**

Thermostat Demand	Blower Speed Adjustments	DIP SWITCH SETTINGS		
		17	18	19
High Heat (R to W1 & W2)	+15%	On	Off	On
	+7.5%	On	Off	Off
	Normal	Off	Off	Off
	-7.5%	On	On	Off
	-15%	On	On	On

**On-Board Link W914 -- Figure 46**

On-board link W914, is a clippable connection between terminals DS and R on the integrated control. W914 must be cut when the furnace is installed with either the Harmony III™ zone control or a thermostat which features humidity control. If the link is left intact the PMW signal from the Harmony III control will be blocked and also lead to control damage. Refer to table 19 for operation sequence in applications including G71MPP, a thermostat which features humidity control and a single-speed outdoor unit. Table 20 gives the operation sequence in applications with a two-speed outdoor unit.

**On-Board Link W951 -- Figure 46**

On-board link W951 is a clippable connection between terminals R and O on the integrated control. W951 must be cut when the furnace is installed in applications which include a heat pump unit and a thermostat which features dual fuel use. If the link is left intact, terminal "O" will remain energized eliminating the HEAT MODE in the heat pump.

**On-Board Link W915 -- Figure 46**

On-board link W915 is a clippable connection between terminals Y1 and Y2 on the integrated control. W915 must be cut if two-stage cooling will be used. If the link is not cut the outdoor unit will operate in second-stage cooling only.

**Diagnostic LED -- Figure 46**

The seven-segment diagnostic LED displays operating status, target airflow, error codes and other information. The table on Page 65 lists diagnostic LED codes.

**Diagnostic Push Button -- Figure 46**

The diagnostic push button is located adjacent to the seven-segment diagnostic LED. This button is used to enable the Error Code Recall mode and the Field Test mode. Press the button and hold it to cycle through a menu of options. Every five seconds a new menu item will be displayed. When the button is released, the displayed item will be selected. Once all items in the menu have been displayed, the menu resumes from the beginning until the button is released.

**Error Code Recall Mode**

Select "E" from the menu to access the most recent 10 error codes. Select "c" from the Error Code Recall menu to clear all error codes. Button must be pressed a second time while "c" is flashing to confirm command to delete codes. Press the button until a solid "≡" is displayed to exit the Error Code Recall mode.

**Field Test Mode**

Use the diagnostic push button to scroll through the menu as described above. Release the button when the LED flashes "-" to select the Field Test mode.

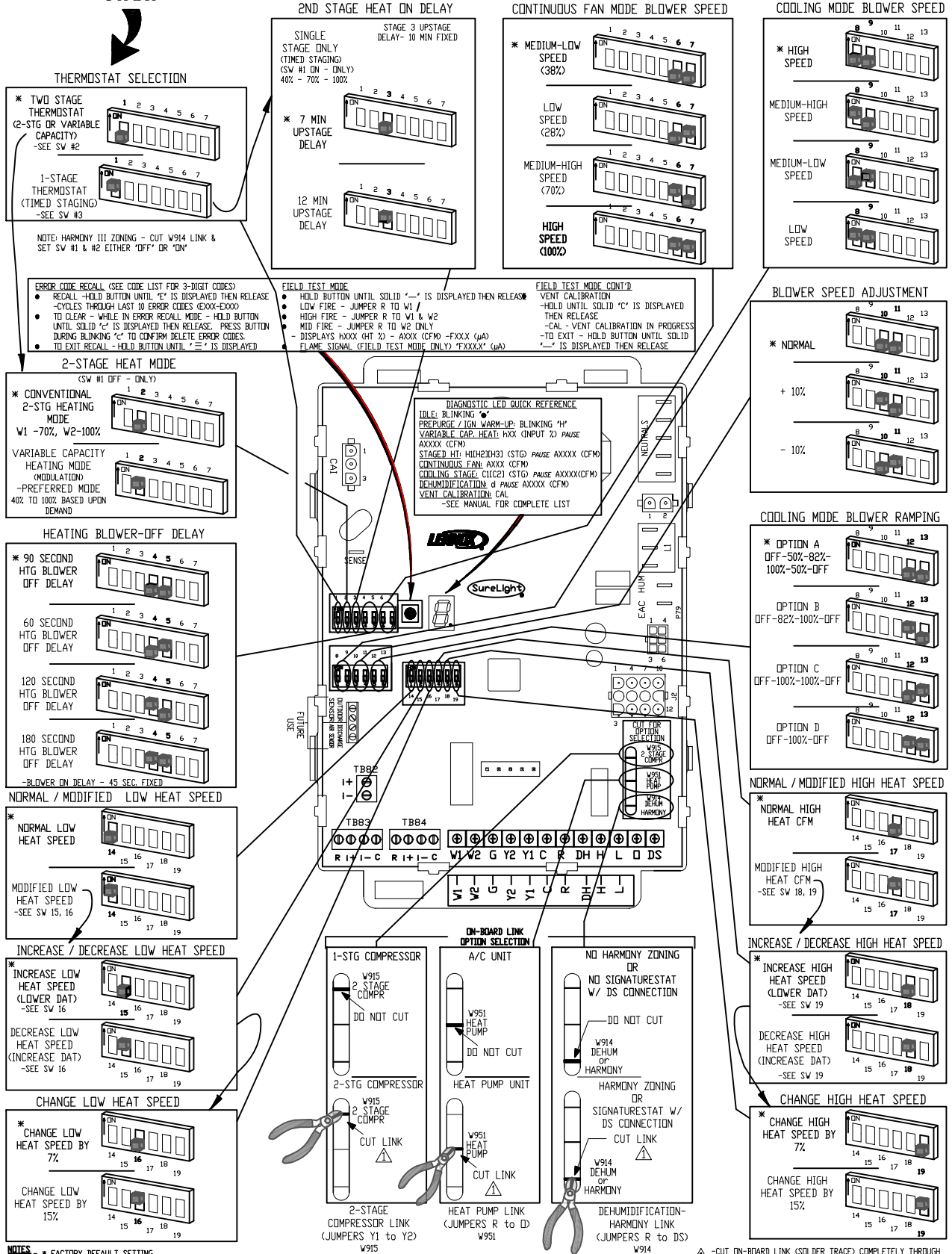
While in the Field Test mode the technician can:

- Initiate furnace ignition and move to and hold low-fire rate by applying a R to W1 jumper.
- Initiate furnace ignition sequence and move to and hold high-fire rate by applying a jumper from R to W1 and W2.
- Initiate furnace ignition sequence and move to and hold mid-fire rate by applying a jumper to R and W2.
- Apply then remove the jumper from R to W1 and W2 to change the firing rate from low fire to mid fire and high fire.
- A vent calibration sequence can be initiated even if a thermostat signal is not present. Press and hold the push button until a solid "C" is displayed. Release the button and calibration will begin. The furnace will perform the high-fire and low-fire pressure switch calibrations and display "CAL". After calibration, the LED will return to the flashing "-" display.

During Field Test mode operation, all safety switches are still in the circuit (they are not by-passed) and indoor blower performance and timings will match DIP switch selections. Current furnace firing rate, indoor blower CFM and flame signal will be displayed. To exit the Field Test mode, press and hold the button. The menu will resume from the beginning. Also, cycle the main power to exit the Field Test mode. The integrated control will automatically exit the Field Test mode after 45 minutes of operation.

# G71MPP INTEGRATED CONTROL CONFIGURATION GUIDE

**START**



**THERMOSTAT SELECTION**

\* TWO STAGE THERMOSTAT (2-STG OR VARIABLE CAPACITY) -SEE SW #2

1-STAGE THERMOSTAT (TIMED STAGING) -SEE SW #3

NOTE: HARMONY III ZONING - CUT W914 LINK & SET SW #1 & #2 EITHER 'OFF' OR 'ON'

**2ND STAGE HEAT ON DELAY**

SINGLE STAGE ONLY (TIMED STAGING) (SW #1 ON - ONLY) 40% - 70% - 100%

STAGE 3 UPSTAGE DELAY - 10 MIN FIXED

\* 7 MIN UPSTAGE DELAY

12 MIN UPSTAGE DELAY

**CONTINUOUS FAN MODE BLOWER SPEED**

\* MEDIUM-LOW SPEED (38%)

LOW SPEED (28%)

MEDIUM-HIGH SPEED (70%)

HIGH SPEED (100%)

**COOLING MODE BLOWER SPEED**

\* HIGH SPEED

MEDIUM-HIGH SPEED

MEDIUM-LOW SPEED

LOW SPEED

**ERROR CODE RECALL (SEE CODE LIST FOR 3-DIGIT CODES)**

- RECALL - HOLD BUTTON UNTIL 'E' IS DISPLAYED THEN RELEASE - CYCLES THROUGH LAST 10 ERROR CODES (E000-E009)
- TO CLEAR - WHILE IN ERROR RECALL MODE - HOLD BUTTON UNTIL SOLID 'C' IS DISPLAYED THEN RELEASE. PRESS BUTTON DURING BLINKING 'C' TO CONFIRM DELETE ERROR CODES.
- TO EXIT RECALL - HOLD BUTTON UNTIL 'E' IS DISPLAYED

**FIELD TEST MODE**

- HOLD BUTTON UNTIL SOLID '-' IS DISPLAYED THEN RELEASE
- LOW FIRE - JUMPER R TO W1
- HIGH FIRE - JUMPER R TO W1 & W2
- MID FIRE - JUMPER R TO W2 ONLY
- DISPLAYS XXXX (HT °F) - XXXX (CFM) - FXXX (WA)
- FLAME SIGNAL (FIELD TEST MODE ONLY) \*FXXX\* (WA)

**FIELD TEST MODE CONT'D**

- VENT CALIBRATION - HOLD UNTIL SOLID 'C' IS DISPLAYED THEN RELEASE
- CAL - VENT CALIBRATION IN PROGRESS
- TO EXIT - HOLD BUTTON UNTIL SOLID '-' IS DISPLAYED THEN RELEASE

**BLOWER SPEED ADJUSTMENT**

\* NORMAL

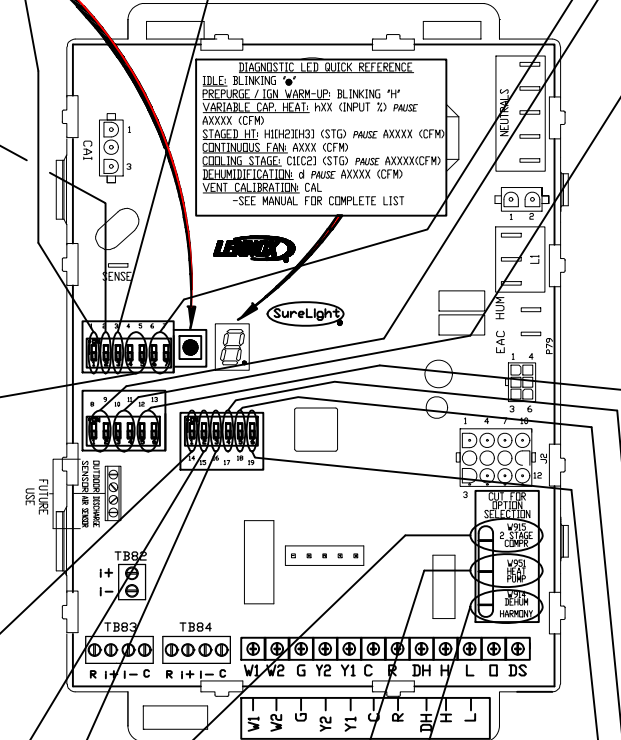
+ 10%

- 10%

**2-STAGE HEAT MODE (SW #1 OFF - ONLY)**

\* CONVENTIONAL 2-STG HEATING MODE W1 - 70%, W2 - 100%

VARIABLE CAPACITY HEATING MODE (MODULATION) -PREFERRED MODE 40% TO 100% BASED UPON DEMAND



**COOLING MODE BLOWER RAMPING**

\* OPTION A OFF-50%-82%-100%-50%-OFF

OPTION B OFF-82%-100%-OFF

OPTION C OFF-100%-100%-OFF

OPTION D OFF-100%-OFF

**HEATING BLOWER-OFF DELAY**

\* 90 SECOND HTG BLOWER OFF DELAY

60 SECOND HTG BLOWER OFF DELAY

120 SECOND HTG BLOWER OFF DELAY

180 SECOND HTG BLOWER OFF DELAY

-BLOWER ON DELAY - 45 SEC FIXED

**NORMAL / MODIFIED HIGH HEAT SPEED**

\* NORMAL HIGH HEAT CFM

MODIFIED HIGH HEAT CFM -SEE SW 18, 19

**NORMAL / MODIFIED LOW HEAT SPEED**

\* NORMAL LOW HEAT SPEED

MODIFIED LOW HEAT SPEED -SEE SW 15, 16

**INCREASE / DECREASE HIGH HEAT SPEED**

\* INCREASE HIGH HEAT SPEED (LOWER DAT) -SEE SW 19

DECREASE HIGH HEAT SPEED (INCREASE DAT) -SEE SW 19

**INCREASE / DECREASE LOW HEAT SPEED**

\* INCREASE LOW HEAT SPEED (LOWER DAT) -SEE SW 16

DECREASE LOW HEAT SPEED (INCREASE DAT) -SEE SW 16

**CHANGE HIGH HEAT SPEED**

\* CHANGE HIGH HEAT SPEED BY 7%

CHANGE HIGH HEAT SPEED BY 15%

**CHANGE LOW HEAT SPEED**

\* CHANGE LOW HEAT SPEED BY 7%

CHANGE LOW HEAT SPEED BY 15%

**NOTES** - \* FACTORY DEFAULT SETTING -SEE INTEGRATED CONTROL DETAILED SETUP INFORMATION FOR COMPLETE SETUP & CONFIGURATION DETAILS.

-PROTECTIVE PLASTIC FILM ON DIP SWITCHES MAY BE REMOVED FOR EASE IN SETTING OF DIP SW.

580049-01 2/08

⚠ CUT ON-BOARD LINK (SOLDER TRACE) COMPLETELY THROUGH BOTH LAYERS ON THE CONTROL BOARD -LINKS CUT IN ERROR -INSTALL A JUMPER ON THE APPROPRIATE TERMINALS ON THE TERMINAL STRIP

FIGURE 47

**TABLE 19  
OPERATING SEQUENCE  
G71MPP, ComfortSense™ 7000 Thermostat and Single-Stage Outdoor Unit**

OPERATING SEQUENCE		SYSTEM DEMAND							SYSTEM RESPONSE			
System Condition	Step	Thermostat Demand					Relative Humidity		Compressor	Blower CFM (COOL)	Comments	
		Y1		O	G	W1	Status	D				
<i>NO CALL FOR DEHUMIDIFICATION</i>												
Normal Operation	1	On		On	On			Acceptable	24 VAC	High	100%	Compressor and indoor blower follow thermostat demand
<i>BASIC MODE (only active on a Y1 thermostat demand)</i>												
Normal Operation	1	On		On	On			Acceptable	24 VAC	High	100%	ComfortSense™ 7000 thermostat energizes Y1 and de-energizes D on a call for de-humidification
Dehumidification Call	2	On		On	On			Demand	0 VAC	High	70%	
<i>PRECISION MODE (operates independent of a Y1 thermostat demand)</i>												
Normal Operation	1	On		On	On			Acceptable	24 VAC	High	100%	Dehumidification mode begins when humidity is greater than set point
Dehumidification call	2	On		On	On			Demand	0 VAC	High	70%	
Dehumidification call ONLY	1	On		On	On			Demand	0 VAC	High	70%	ComfortSense™ 7000 thermostat will keep outdoor unit energized after cooling temperature setpoint has been reached in order to maintain room humidity set-point.
	On-board links at indoor unit with a single-stage outdoor unit: With Condensing unit - Cut W914 (R to DS) on SureLight® integrated control; With Heat Pump - Cut W914 (R to DS) & W951 (R to O) on SureLight® integrated control.											

**TABLE 20  
OPERATING SEQUENCE  
G71MPP, ComfortSense™ 7000 Thermostat and Two-Stage Outdoor Unit**

OPERATING SEQUENCE		SYSTEM DEMAND								SYSTEM RESPONSE		
System Condition	Step	Thermostat Demand						Relative Humidity		Compressor	Blower CFM (COOL)	Comments
		Y1	Y2	O	G	W 1	W 2	Status	D			
<b>NO CALL FOR DEHUMIDIFICATION</b>												
Normal Operation - Y1	1	On		On	On			Acceptable	24 VAC	Low	70%	Compressor and indoor blower follow thermostat demand
Normal Operation - Y2	2	On	On	On	On			Acceptable	24 VAC	High	100%	
<b>ROOM THERMOSTAT CALLS FOR FIRST STAGE COOLING</b>												
<i>BASIC MODE (only active on a Y1 thermostat demand)</i>												
Normal Operation	1	On		On	On			Acceptable	24 VAC	Low	70%	ComfortSense™ 7000 thermostat energizes Y2 and de-energizes D on a call for de-humidification
Dehumidification Call	2	On	On	On	On			Demand	0 VAC	High	70%	
<i>PRECISION MODE (operates independent of a Y1 thermostat demand)</i>												
Normal Operation	1	On		On	On			Acceptable	24 VAC	Low	70%	Dehumidification mode begins when humidity is greater than set point
Dehumidification call	2	On	On	On	On			Demand	0 VAC	High	70%	
Dehumidification call ONLY	1	On	On	On	On			Demand	0 VAC	High	70%	ComfortSense™ 7000 thermostat will keep outdoor unit energized after cooling temperature set-point has been reached in order to maintain room humidity setpoint.*
<b>ROOM THERMOSTAT CALLS FOR FIRST AND SECOND STAGE COOLING</b>												
<i>BASIC MODE (only active on a Y1 thermostat demand)</i>												
Normal Operation	1	On	On	On	On			Acceptable	24 VAC	High	100%	ComfortSense™ 7000 thermostat energizes Y2 and de-energizes D on a call for de-humidification
Dehumidification Call	2	On	On	On	On			Demand	0 VAC	High	70%	
<i>PRECISION MODE (operates independent of a Y1 thermostat demand)</i>												
Normal Operation	1	On		On	On			Acceptable	24 VAC	Low	70%	Dehumidification mode begins when humidity is greater than set point
Dehumidification call	2	On	On	On	On			Demand	0 VAC	High	70%	
Dehumidification call ONLY	1	On	On	On	On			Demand	0 VAC	High	70%	ComfortSense™ 7000 thermostat will keep outdoor unit energized after cooling temperature set-point has been reached in order to maintain room humidity setpoint.
	On-board links at indoor unit with a two-stage outdoor unit: Cut factory link from Y1 to Y2 or cut W915 (Y1 to Y2) on SureLight® integrated control. With Condensing unit - Cut W914 (R to DS) on SureLight® integrated control; With Heat Pump - Cut W914 (R to DS) & W951 (R to O) on SureLight® integrated control.											

## Blower Motor Performance

**TABLE 21**  
**G71MPP-36B-070 BLOWER PERFORMANCE** (less filter)  
**0 through 0.80 in. w.g. External Static Pressure Range**

### HEATING BLOWER PERFORMANCE

Heating Adjust CFM Selections	Heating Input Range and Blower Volume - CFM						
	40%	50%	60%	70%	80%	90%	100%
Increase (+15%) Heat CFM	535	610	690	770	870	975	1075
Increase (+7.5%) Heat CFM	505	575	645	720	810	905	1000
Default Heat CFM	480	545	610	675	760	845	930
Decrease (-7.5%) Heat CFM	460	520	580	640	715	790	870
Decrease (-15%) Heat CFM	440	490	540	590	655	715	780

### COOLING BLOWER PERFORMANCE

Cooling Adjust CFM Selections	Blower Speed Selections							
	First Stage Cool Speed - cfm				Second Stage Cool Speed - cfm			
	Low	Medium-Low	Medium High	High (Default)	Low	Medium-Low	Medium High	High (Default)
Increase (+10%) Cool CFM	730	815	865	935	1015	1190	1280	1395
Default Cool CFM	680	755	795	855	930	1065	1155	1270
Decrease (-10%) Cool CFM	625	695	730	775	830	950	1010	1105

The effect of static pressure is included in air volumes shown.

Lennox Harmony III™ Zone Control Applications - Minimum blower speed is 300 cfm.

The following control configurations are available. See Installation Instructions for details and DIP switch settings.

**Heat Mode** (Heating Blower Performance Table):

With a single-stage thermostat, furnace will operate at three, staged rates (40/70/100%) with a time delay between each stage (values in grey-shaded columns).

With two-stage thermostat there are two modes available.

Traditional two-stage mode - W1 result in 70% firing rate. W2 results in 100% firing rate. No delay between stages. (values shown in 70% and 100% grey-shaded columns only).

Variable Rate Capacity Mode - furnace automatically adjusts firing rate based on first- and second-stage cycle times. (all columns)

**Cool Mode** (Cooling Blower Performance table):

First stage COOL (two-stage air conditioning units only) is approximately 70% of the same second stage COOL speed position.

Continuous Fan speeds are approximately 28%, 38%, 70% and 100% (DIP switch selectable) of the same second-stage COOL speed position minimum 250 cfm.

### G71MPP-36B-070 BLOWER MOTOR WATTS - COOLING

Blower Speed Options	Motor Watts @ Various External Static Pressures - in. wg.																	
	First Stage									Second Stage								
	0	0.10	0.20	0.30	0.40	0.50	0.60	0.70	0.80	0	0.10	0.20	0.30	0.40	0.50	0.60	0.70	0.80
<b>Increase (+10%) Cool CFM</b>																		
Low	55	70	90	110	130	145	160	175	190	135	155	175	200	220	245	270	295	320
Medium-Low	75	90	110	130	150	170	190	205	220	185	215	250	285	315	345	370	395	420
Medium-High	85	100	120	145	165	185	205	225	250	235	265	300	335	370	400	425	455	480
High	105	125	150	170	190	210	235	255	280	315	340	370	395	440	480	510	540	570
<b>Default Cool CFM</b>																		
Low	45	60	80	95	115	130	145	160	175	100	120	140	165	190	215	235	255	275
Medium-Low	60	75	95	110	130	145	165	180	200	140	165	190	220	245	265	290	315	340
Medium-High	65	85	105	125	140	155	175	195	215	175	200	230	260	285	310	340	365	390
High	85	100	120	140	160	180	200	220	240	230	260	295	325	360	390	410	435	455
<b>Decrease (-10%) Cool CFM</b>																		
Low	40	55	70	85	100	120	130	145	160	75	90	110	125	150	175	190	210	225
Medium-Low	45	60	80	95	115	135	145	160	175	95	120	150	175	200	220	240	260	285
Medium-High	50	65	85	105	125	145	160	175	190	125	150	175	195	220	240	265	290	320
High	60	75	95	115	135	150	170	190	215	165	190	215	245	265	485	315	340	370

**TABLE 22**  
**G71MPP-36C-090 BLOWER PERFORMANCE (less filter)**  
**0 through 0.80 in. w.g. External Static Pressure Range**

**HEATING BLOWER PERFORMANCE**

Heating Adjust CFM Selections	Heating Input Range and Blower Volume - CFM						
	40%	50%	60%	70%	80%	90%	100%
Increase (+15%) Heat CFM	650	740	825	910	1005	1100	1200
Increase (+7.5%) Heat CFM	620	695	775	850	940	1025	1115
Default Heat CFM	590	655	725	790	870	950	1030
Decrease (-7.5%) Heat CFM	555	615	680	740	815	890	965
Decrease (-15%) Heat CFM	525	575	630	680	745	805	870

**COOLING BLOWER PERFORMANCE**

Cooling Adjust CFM Selections	Blower Speed Selections							
	First Stage Cool Speed - cfm				Second Stage Cool Speed - cfm			
	Low	Medium-Low	Medium High	High (Default)	Low	Medium-Low	Medium High	High (Default)
Increase (+10%) Cool CFM	705	790	845	920	1020	1185	1275	1395
Default Cool CFM	650	730	770	830	905	1060	1145	1270
Decrease (-10%) Cool CFM	600	670	705	750	800	925	1010	1100

The effect of static pressure is included in air volumes shown.

Lennox Harmony III™ Zone Control Applications - Minimum blower speed is 300 cfm.

The following control configurations are available. See Installation Instructions for details and DIP switch settings.

**Heat Mode** (Heating Blower Performance Table):

With a single-stage thermostat, furnace will operate at three, staged rates (40/70/100%) with a time delay between each stage (values in grey-shaded columns).

With two-stage thermostat there are two modes available.

Traditional two-stage mode - W1 demand results in 70% firing rate. W2 results in 100% firing rate. No delay between stages. (values shown in 70% and 100% grey-shaded columns only).

Variable Rate Capacity Mode - furnace automatically adjusts firing rate based on first- and second-stage cycle times. (all columns)

**Cool Mode** (Cooling Blower Performance table):

First stage COOL (two-stage air conditioning units only) is approximately 70% of the same second stage COOL speed position.

Continuous Fan speeds are approximately 28%, 38%, 70% and 100% (DIP switch selectable) of the same second-stage COOL speed position minimum 250 cfm.

**G71MPP-36C-090 BLOWER MOTOR WATTS - COOLING**

Blower Speed Options	Motor Watts @ Various External Static Pressures - in. wg.																	
	First Stage										Second Stage							
	0	0.10	0.20	0.30	0.40	0.50	0.60	0.70	0.80	0	0.10	0.20	0.30	0.40	0.50	0.60	0.70	0.80
<b>Increase (+10%) Cool CFM</b>																		
Low	35	50	70	90	105	125	140	160	175	85	110	135	160	185	205	235	265	295
Medium-Low	45	60	80	100	125	150	170	185	205	125	155	185	220	245	275	305	330	360
Medium-High	60	75	95	110	135	160	180	200	220	165	195	230	265	300	330	355	380	410
High	65	85	110	135	160	180	205	225	245	210	245	285	325	360	390	425	460	495
<b>Default Cool CFM</b>																		
Low	35	45	60	75	95	115	130	145	160	60	80	110	135	155	175	195	215	235
Medium-Low	40	55	70	90	110	130	150	165	185	105	125	145	170	200	225	250	270	295
Medium-High	45	60	80	95	115	135	155	175	195	115	140	175	205	235	265	290	315	335
High	50	65	85	105	130	155	180	200	220	155	185	220	255	285	315	345	380	415
<b>Decrease (-10%) Cool CFM</b>																		
Low	30	40	55	75	90	105	120	135	150	55	65	85	105	125	150	170	190	210
Medium-Low	40	50	65	80	100	120	130	145	160	65	90	120	145	165	185	205	225	250
Medium-High	40	55	70	90	105	125	140	160	180	85	105	135	165	185	210	235	260	285
High	45	60	75	90	115	135	155	170	190	105	125	150	175	210	240	275	305	335

**TABLE 23**  
**G71MPP-60C-090 BLOWER PERFORMANCE** (less filter)  
**Bottom Return Air, Return Air from Both Sides or Return Air from Bottom and One Side**  
**0 through 0.80 in. w.g. External Static Pressure Range**

<b>HEATING BLOWER PERFORMANCE</b>							
Heating Adjust CFM Selections	Heating Input Range and Blower Volume - CFM						
	40%	50%	60%	70%	80%	90%	100%
Increase (+15%) Heat CFM	665	800	935	1070	1205	1335	1470
Increase (+7.5%) Heat CFM	600	730	860	990	1110	1235	1355
Default Heat CFM	615	715	820	920	1035	1150	1265
Decrease (-7.5%) Heat CFM	520	630	740	850	960	1070	1180
Decrease (-15%) Heat CFM	465	565	665	765	870	970	1075

<b>COOLING BLOWER PERFORMANCE</b>								
Cooling Adjust CFM Selections	Blower Speed Selections							
	First Stage Cool Speed - cfm				Second Stage Cool Speed - cfm			
	Low	Medium-Low	Medium High	High (Default)	Low	Medium-Low	Medium High	High (Default)
Increase (+10%) Cool CFM	1105	1185	1355	1545	1605	1710	1925	2165
Default Cool CFM	995	1080	1205	1345	1440	1560	1755	1960
Decrease (-10%) Cool CFM	890	960	1090	1215	1275	1380	1590	1755

The effect of static pressure is included in air volumes shown.  
 Lennox Harmony III™ Zone Control Applications - Minimum blower speed is 400 cfm.  
 The following control configurations are available. See Installation Instructions for details and DIP switch settings.  
**Heat Mode** (Heating Blower Performance Table):  
 With a single-stage thermostat, furnace will operate at three, staged rates (40/70/100%) with a time delay between each stage (values in grey-shaded columns).  
 With two-stage thermostat there are two modes available.  
 Traditional two-stage mode - W1 demand results in 70% firing rate. W2 results in 100% firing rate. No delay between stages. (values shown in 70% and 100% grey-shaded columns only).  
 Variable Rate Capacity Mode - furnace automatically adjusts firing rate based on first- and second-stage cycle times. (all columns)  
**Cool Mode** (Cooling Blower Performance table):  
 First stage COOL (two-stage air conditioning units only) is approximately 70% of the same second stage COOL speed position.  
 Continuous Fan speeds are approximately 28%, 38%, 70% and 100% (DIP switch selectable) of the same second-stage COOL speed position minimum 450 cfm.

**G71MPP-60C-090 BLOWER MOTOR WATTS - COOLING**  
**Bottom Return Air, Return Air from Both Sides or Return Air from Bottom and One Side**

Blower Speed Options	Motor Watts @ Various External Static Pressures - in. wg.																	
	First Stage									Second Stage								
	0	0.10	0.20	0.30	0.40	0.50	0.60	0.70	0.80	0	0.10	0.20	0.30	0.40	0.50	0.60	0.70	0.80
<b>Increase (+10%) Cool CFM</b>																		
Low	115	135	160	185	205	230	255	275	300	305	340	375	410	440	475	505	535	565
Medium-Low	145	165	190	215	240	265	285	305	325	355	390	430	470	510	550	580	610	635
Medium-High	170	200	240	275	305	335	370	400	430	510	555	600	645	690	730	765	795	830
High	265	295	330	365	400	435	465	500	535	725	780	835	895	935	975	1005	1035	1065
<b>Default Cool CFM</b>																		
Low	90	110	130	155	175	195	215	235	255	220	250	285	320	350	385	415	450	485
Medium-Low	110	130	155	180	200	220	245	265	285	270	305	345	385	420	455	485	515	545
Medium-High	145	165	190	215	245	270	295	320	340	390	425	465	500	540	580	610	640	670
High	180	205	240	270	300	330	365	395	430	540	580	625	670	710	755	795	830	870
<b>Decrease (-10%) Cool CFM</b>																		
Low	70	85	105	125	145	165	185	205	225	160	190	220	255	275	300	330	360	390
Medium-Low	80	100	120	140	165	190	210	225	245	195	225	260	295	325	350	385	415	450
Medium-High	110	130	160	185	205	225	250	275	300	295	330	365	400	430	460	495	535	570
High	155	175	195	220	245	270	295	315	340	400	435	470	510	545	585	610	640	665

**TABLE 24**  
**G71MPP-60C-090 BLOWER PERFORMANCE (less filter) -- Single Side Return Air**  
(Air volumes in bold require field fabricated transition to accommodate 20 x 25 x 1 in. cleanable air filter  
in order to maintain proper air velocity across the filter.)  
**0 through 0.80 in. w.g. External Static Pressure Range**

**HEATING BLOWER PERFORMANCE**

Heating Adjust CFM Selections	Heating Input Range and Blower Volume - CFM						
	40%	50%	60%	70%	80%	90%	100%
<b>Increase (+15%) Heat CFM</b>	655	790	920	1050	1180	1310	1440
<b>Increase (+7.5%) Heat CFM</b>	605	725	850	970	1090	1205	1325
<b>Default Heat CFM</b>	555	675	790	905	1015	1125	1235
<b>Decrease (-7.5% ) Heat CFM</b>	515	625	730	835	940	1045	1150
<b>Decrease (-15% ) Heat CFM</b>	465	565	665	765	860	960	1055

**COOLING BLOWER PERFORMANCE**

Cooling Adjust CFM Selections	Blower Speed Selections							
	First Stage Cool Speed - cfm				Second Stage Cool Speed - cfm			
	Low	Medium-Low	Medium High	High (Default)	Low	Medium-Low	Medium High	High (Default)
<b>Increase (+10%) Cool CFM</b>	1080	1160	1315	1490	1575	1690	<b>1895</b>	<b>2135</b>
<b>Default Cool CFM</b>	985	1060	1185	1330	1405	1530	1735	<b>1935</b>
<b>Decrease (-10%) Cool CFM</b>	865	930	1065	1185	1250	1355	1560	1735

The effect of static pressure is included in air volumes shown.

Lennox Harmony III™ Zone Control Applications - Minimum blower speed is 400 cfm.

The following control configurations are available. See Installation Instructions for details and DIP switch settings.

**Heat Mode** (Heating Blower Performance Table):

With a single-stage thermostat, furnace will operate at three, staged rates (40/70/100%) with a time delay between each stage (values in grey-shaded columns).

With two-stage thermostat there are two modes available.

Traditional two-stage mode - W1 demand results in 70% firing rate. W2 results in 100% firing rate. No delay between stages. (values shown in 70% and 100% grey-shaded columns only).

Variable Rate Capacity Mode - furnace automatically adjusts firing rate based on first- and second-stage cycle times. (all columns)

**Cool Mode** (Cooling Blower Performance table):

First stage COOL (two-stage air conditioning units only) is approximately 70% of the same second stage COOL speed position.

Continuous Fan speeds are approximately 28%, 38%, 70% and 100% (DIP switch selectable) of the same second-stage COOL speed position minimum 450 cfm.

**G71MPP-60C-090 BLOWER MOTOR WATTS - COOLING**

Blower Speed Options	Motor Watts @ Various External Static Pressures - in. wg.																	
	First Stage									Second Stage								
	0	0.10	0.20	0.30	0.40	0.50	0.60	0.70	0.80	0	0.10	0.20	0.30	0.40	0.50	0.60	0.70	0.80
<b>Increase (+10%) Cool CFM</b>																		
Low	110	130	155	180	205	225	245	270	290	285	320	355	390	430	465	500	535	565
Medium-Low	125	150	175	205	225	250	275	300	325	355	390	430	470	500	530	570	605	645
Medium-High	170	195	230	260	290	325	355	385	415	515	550	590	625	670	710	750	795	840
High	240	275	315	355	380	405	445	485	525	740	785	835	885	920	955	990	1020	1050
<b>Default Cool CFM</b>																		
Low	85	100	125	145	170	200	215	235	255	200	230	270	310	340	370	400	430	460
Medium-Low	105	125	150	170	195	220	240	260	280	260	295	330	365	400	440	470	500	530
Medium-High	135	160	185	215	240	270	290	315	335	410	440	470	500	540	580	610	640	670
High	170	200	235	265	305	340	365	390	415	550	585	620	655	695	740	780	825	865
<b>Decrease (-10%) Cool CFM</b>																		
Low	65	80	100	120	140	160	180	205	225	180	215	245	265	290	320	345	375	445
Medium-Low	75	90	110	130	155	180	200	220	245	220	250	275	305	335	370	400	430	510
Medium-High	100	120	150	175	200	220	245	265	290	320	350	385	415	445	485	520	560	635
High	135	160	185	215	240	265	290	315	335	435	465	495	540	585	610	640	665	765



**TABLE 25**  
**G71MPP-60C-090 BLOWER PERFORMANCE (less filter) -- Side Return Air with Optional RAB Return Air Base**  
**0 through 0.80 in. w.g. External Static Pressure Range**

**HEATING BLOWER PERFORMANCE**

Heating Adjust CFM Selections	Heating Input Range and Blower Volume - CFM						
	40%	50%	60%	70%	80%	90%	100%
Increase (+15%) Heat CFM	645	770	895	1020	1155	1290	1425
Increase (+7.5%) Heat CFM	595	710	825	945	1070	1195	1315
Default Heat CFM	545	660	775	890	1005	1115	1225
Decrease (-7.5%) Heat CFM	505	605	710	810	920	1030	1140
Decrease (-15%) Heat CFM	455	555	650	750	845	945	1045

**COOLING BLOWER PERFORMANCE**

Cooling Adjust CFM Selections	Blower Speed Selections							
	First Stage Cool Speed - cfm				Second Stage Cool Speed - cfm			
	Low	Medium-Low	Medium High	High (Default)	Low	Medium-Low	Medium High	High (Default)
Increase (+10%) Cool CFM	1060	1135	1285	1455	1525	1655	1860	2100
Default Cool CFM	960	1035	1165	1310	1385	1500	1695	1905
Decrease (-10%) Cool CFM	865	920	1050	1165	1240	1320	1510	1695

The effect of static pressure is included in air volumes shown.

Lennox Harmony III™ Zone Control Applications - Minimum blower speed is 400 cfm.

The following control configurations are available. See Installation Instructions for details and DIP switch settings.

**Heat Mode** (Heating Blower Performance Table):

With a single-stage thermostat, furnace will operate at three, staged rates (40/70/100%) with a time delay between each stage (values in grey-shaded columns).

With two-stage thermostat there are two modes available.

Traditional two-stage mode - W1 demand results in 70% firing rate. W2 results in 100% firing rate. No delay between stages. (values shown in 70% and 100% grey-shaded columns only).

Variable Rate Capacity Mode - furnace automatically adjusts firing rate based on first- and second-stage cycle times. (all columns)

**Cool Mode** (Cooling Blower Performance table):

First stage COOL (two-stage air conditioning units only) is approximately 70% of the same second stage COOL speed position.

Continuous Fan speeds are approximately 28%, 38%, 70% and 100% (DIP switch selectable) of the same second-stage COOL speed position minimum 450 cfm.

**G71MPP-60C-090 BLOWER MOTOR WATTS - COOLING**

Side Return Air with Optional RAB Return Air Base

Blower Speed Options	Motor Watts @ Various External Static Pressures - in. wg.																	
	First Stage									Second Stage								
	0	0.10	0.20	0.30	0.40	0.50	0.60	0.70	0.80	0	0.10	0.20	0.30	0.40	0.50	0.60	0.70	0.80
<b>Increase (+10%) Cool CFM</b>																		
Low	110	130	150	175	195	215	240	265	290	275	305	340	380	410	440	470	505	540
Medium-Low	130	155	175	200	220	245	265	290	315	360	390	420	455	485	515	550	590	625
Medium-High	160	190	220	255	280	305	335	360	390	490	530	570	610	645	680	715	750	785
High	220	255	295	330	365	400	430	460	490	695	750	805	855	895	935	965	995	1025
<b>Default Cool CFM</b>																		
Low	80	95	120	140	165	190	210	235	255	190	225	265	305	330	355	390	420	455
Medium-Low	100	120	140	165	190	215	235	255	275	265	295	325	355	390	420	455	495	530
Medium-High	140	160	185	205	235	260	285	305	325	375	410	440	475	500	530	570	610	650
High	180	205	240	270	300	325	350	380	405	520	560	605	645	685	720	760	805	845
<b>Decrease (-10%) Cool CFM</b>																		
Low	70	85	105	125	140	160	180	200	220	155	175	200	225	255	290	315	340	365
Medium-Low	80	95	115	135	155	175	200	220	245	185	210	235	260	295	325	355	385	415
Medium-High	105	125	150	175	200	220	240	265	290	255	290	330	365	400	430	460	490	520
High	135	160	185	215	235	260	285	305	330	370	400	440	475	505	530	565	600	635

**TABLE 26**  
**G71MPP-60C-110 BLOWER PERFORMANCE** (less filter)  
**Bottom Return Air, Return Air from Both Sides or Return Air from Bottom and One Side**  
**0 through 0.80 in. w.g. External Static Pressure Range**

**HEATING BLOWER PERFORMANCE**

Heating Adjust CFM Selections	Heating Input Range and Blower Volume - CFM						
	40%	50%	60%	70%	80%	90%	100%
Increase (+15%) Heat CFM	890	1050	1215	1375	1535	1695	1855
Increase (+7.5%) Heat CFM	845	975	1125	1275	1430	1585	1740
Default Heat CFM	800	960	1075	1190	1335	1480	1625
Decrease (-7.5%) Heat CFM	735	860	990	1120	1250	1380	1510
Decrease (-15%) Heat CFM	670	790	910	1030	1145	1260	1375

**COOLING BLOWER PERFORMANCE**

Cooling Adjust CFM Selections	Blower Speed Selections							
	First Stage Cool Speed - cfm				Second Stage Cool Speed - cfm			
	Low	Medium-Low	Medium High	High (Default)	Low	Medium-Low	Medium High	High (Default)
Increase (+10%) Cool CFM	945	1020	1160	1300	1625	1745	1990	2210
Default Cool CFM	840	910	1055	1180	1465	1580	1790	1995
Decrease (-10%) Cool CFM	740	800	920	1045	1290	1405	1605	1790

The effect of static pressure is included in air volumes shown.

Lennox Harmony III™ Zone Control Applications - Minimum blower speed is 475 cfm.

The following control configurations are available. See Installation Instructions for details and DIP switch settings.

**Heat Mode** (Heating Blower Performance Table):

With a single-stage thermostat, furnace will operate at three, staged rates (40/70/100%) with a time delay between each stage (values in grey-shaded columns).

With two-stage thermostat there are two modes available.

Traditional two-stage mode - W1 demand results in 70% firing rate. W2 results in 100% firing rate. No delay between stages. (values shown in 70% and 100% grey-shaded columns only).

Variable Rate Capacity Mode - furnace automatically adjusts firing rate based on first- and second-stage cycle times. (all columns)

**Cool Mode** (Cooling Blower Performance table):

First stage COOL (two-stage air conditioning units only) is approximately 70% of the same second stage COOL speed position.

Continuous Fan speeds are approximately 28%, 38%, 70% and 100% (DIP switch selectable) of the same second-stage COOL speed position minimum 450 cfm.

**G71MPP-60C-110 BLOWER MOTOR WATTS - COOLING**

**Bottom Return Air, Return Air from Both Sides or Return Air from Bottom and One Side**

Blower Speed Options	Motor Watts @ Various External Static Pressures - in. wg.																	
	First Stage								Second Stage									
	0	0.10	0.20	0.30	0.40	0.50	0.60	0.70	0.80	0	0.10	0.20	0.30	0.40	0.50	0.60	0.70	0.80
<b>Increase (+10%) Cool CFM</b>																		
Low	75	90	115	135	160	180	200	220	240	280	315	350	390	430	475	510	550	585
Medium-Low	90	105	130	150	175	200	220	245	270	340	380	425	465	505	545	575	610	645
Medium-High	120	140	170	195	225	250	275	300	330	510	545	585	620	675	735	770	805	840
High	160	185	210	235	265	290	325	360	395	710	755	805	855	905	950	980	1010	1035
<b>Default Cool CFM</b>																		
Low	55	70	90	110	135	155	175	195	215	205	235	275	310	345	380	415	450	485
Medium-Low	75	90	105	125	150	170	190	215	235	250	285	325	360	400	440	470	505	540
Medium-High	95	115	135	160	190	220	240	265	285	375	410	445	485	530	575	605	635	670
High	125	150	175	200	225	255	280	305	335	510	550	595	640	685	725	770	815	860
<b>Decrease (-10%) Cool CFM</b>																		
Low	45	60	80	100	115	125	145	160	180	155	180	210	240	270	295	325	355	385
Medium-Low	55	70	85	105	125	150	165	185	200	185	215	245	280	315	345	380	415	450
Medium-High	70	85	105	125	150	170	195	215	235	265	300	345	385	425	465	500	535	570
High	95	110	135	160	190	220	240	260	280	375	415	455	495	535	575	615	650	690

**TABLE 27**  
**71MPP-60C-110 BLOWER PERFORMANCE (less filter) -- Single Side Return Air**  
(Air volumes in bold require field fabricated transition to accommodate 20 x 25 x 1 in. cleanable air filter in order to maintain proper air velocity across the filter.)  
**0 through 0.80 in. w.g. External Static Pressure Range**

**HEATING BLOWER PERFORMANCE**

Heating Adjust CFM Selections	Heating Input Range and Blower Volume - CFM						
	40%	50%	60%	70%	80%	90%	100%
Increase (+15%) Heat CFM	870	1030	1185	1345	1490	1630	1775
Increase (+7.5%) Heat CFM	815	955	1095	1240	1380	1525	1670
Default Heat CFM	765	900	1035	1170	1305	1435	1570
Decrease (-7.5%) Heat CFM	715	840	965	1090	1210	1330	1450
Decrease (-15%) Heat CFM	650	765	880	995	1110	1225	1335

**COOLING BLOWER PERFORMANCE**

Cooling Adjust CFM Selections	Blower Speed Selections							
	First Stage Cool Speed - cfm				Second Stage Cool Speed - cfm			
	Low	Medium-Low	Medium High	High (Default)	Low	Medium-Low	Medium High	High (Default)
Increase (+10%) Cool CFM	935	1025	1155	1285	1585	1700	<b>1905</b>	<b>2135</b>
Default Cool CFM	840	915	1050	1175	1435	1535	1740	<b>1930</b>
Decrease (-10%) Cool CFM	750	800	925	1050	1280	1385	1570	1755

The effect of static pressure is included in air volumes shown.

Lennox Harmony III™ Zone Control Applications - Minimum blower speed is 475 cfm.

The following control configurations are available. See Installation Instructions for details and DIP switch settings.

**Heat Mode** (Heating Blower Performance Table):

With a single-stage thermostat, furnace will operate at three, staged rates (40/70/100%) with a time delay between each stage (values in grey-shaded columns).

With two-stage thermostat there are two modes available.

Traditional two-stage mode - W1 demand results in 70% firing rate. W2 results in 100% firing rate. No delay between stages. (values shown in 70% and 100% grey-shaded columns only).

Variable Rate Capacity Mode - furnace automatically adjusts firing rate based on first- and second-stage cycle times. (all columns)

**Cool Mode** (Cooling Blower Performance table):

First stage COOL (two-stage air conditioning units only) is approximately 70% of the same second stage COOL speed position.

Continuous Fan speeds are approximately 28%, 38%, 70% and 100% (DIP switch selectable) of the same second-stage COOL speed position minimum 450 cfm.

**71MPP-60C-110 BLOWER MOTOR WATTS - COOLING**

Blower Speed Options	Motor Watts @ Various External Static Pressures - in. wg.																	
	First Stage									Second Stage								
	0	0.10	0.20	0.30	0.40	0.50	0.60	0.70	0.80	0	0.10	0.20	0.30	0.40	0.50	0.60	0.70	0.80
<b>Increase (+10%) Cool CFM</b>																		
Low	70	90	110	130	150	165	185	210	230	255	295	345	390	430	470	510	545	585
Medium-Low	85	105	125	150	170	190	215	235	255	340	375	415	455	490	525	570	615	660
Medium-High	115	135	160	185	210	230	255	285	310	455	500	555	610	655	695	750	800	850
High	155	175	195	220	250	285	310	335	360	650	710	770	835	880	920	960	995	1035
<b>Default Cool CFM</b>																		
Low	60	75	90	110	125	145	165	185	205	195	230	270	305	345	380	415	455	490
Medium-Low	70	85	105	125	140	160	180	200	220	225	265	315	360	400	440	475	515	555
Medium-High	95	110	130	150	175	200	225	245	265	365	400	445	485	525	565	610	650	690
High	115	135	165	190	215	235	260	285	310	495	535	580	625	675	725	770	815	860
<b>Decrease (-10%) Cool CFM</b>																		
Low	45	60	80	100	110	125	140	155	170	155	180	205	235	270	305	340	370	400
Medium-Low	50	65	85	100	120	135	155	175	195	170	200	240	275	315	355	390	420	455
Medium-High	75	90	105	120	140	160	185	210	235	250	290	330	375	410	445	485	525	570
High	95	110	135	155	175	200	225	250	270	365	405	450	490	535	575	615	655	690

**TABLE 28**  
**G71MPP-60C-110 BLOWER PERFORMANCE (less filter) -- Side Return Air with Optional RAB Return Air Base**  
**0 through 0.80 in. w.g. External Static Pressure Range**

<b>HEATING BLOWER PERFORMANCE</b>							
Heating Adjust CFM Selections	Heating Input Range and Blower Volume - CFM						
	40%	50%	60%	70%	80%	90%	100%
Increase (+15%) Heat CFM	865	1020	1175	1330	1485	1635	1785
Increase (+7.5%) Heat CFM	805	950	1095	1240	1385	1535	1680
Default Heat CFM	760	895	1030	1165	1300	1435	1570
Decrease (-7.5%) Heat CFM	710	835	960	1090	1210	1335	1460
Decrease (-15%) Heat CFM	645	765	880	1000	1110	1220	1335

<b>COOLING BLOWER PERFORMANCE</b>								
Cooling Adjust CFM Selections	Blower Speed Selections							
	First Stage Cool Speed - cfm				Second Stage Cool Speed - cfm			
	Low	Medium-Low	Medium High	High (Default)	Low	Medium-Low	Medium High	High (Default)
Increase (+10%) Cool CFM	1085	1155	1310	1475	1555	1685	1895	2130
Default Cool CFM	955	1050	1185	1335	1415	1540	1735	1930
Decrease (-10%) Cool CFM	850	920	1070	1195	1245	1350	1545	1725

The effect of static pressure is included in air volumes shown.  
 Lennox Harmony III™ Zone Control Applications - Minimum blower speed is 475 cfm.  
 The following control configurations are available. See Installation Instructions for details and DIP switch settings.  
**Heat Mode** (Heating Blower Performance Table):  
 With a single-stage thermostat, furnace will operate at three, staged rates (40/70/100%) with a time delay between each stage (values in grey-shaded columns).  
 With two-stage thermostat there are two modes available.  
 Traditional two-stage mode - W1 demand results in 70% firing rate. W2 results in 100% firing rate. No delay between stages. (values shown in 70% and 100% grey-shaded columns only).  
 Variable Rate Capacity Mode - furnace automatically adjusts firing rate based on first- and second-stage cycle times. (all columns)  
**Cool Mode** (Cooling Blower Performance table):  
 First stage COOL (two-stage air conditioning units only) is approximately 70% of the same second stage COOL speed position.  
 Continuous Fan speeds are approximately 28%, 38%, 70% and 100% (DIP switch selectable) of the same second-stage COOL speed position minimum 450 cfm.

**G71MPP-60C-110 BLOWER MOTOR WATTS - COOLING - Side Return Air with Optional RAB Return Air Base**

Blower Speed Options	Motor Watts @ Various External Static Pressures - in. wg.																	
	First Stage									Second Stage								
	0	0.10	0.20	0.30	0.40	0.50	0.60	0.70	0.80	0	0.10	0.20	0.30	0.40	0.50	0.60	0.70	0.80
<b>Increase (+10%) Cool CFM</b>																		
Low	105	125	150	175	200	220	245	265	290	250	285	320	360	395	435	470	500	535
Medium-Low	130	150	175	200	220	240	270	295	320	335	365	405	445	480	515	550	590	630
Medium-High	165	190	220	250	275	305	335	370	400	470	505	545	585	630	670	710	755	800
High	205	240	285	330	360	390	420	450	485	655	695	745	790	840	885	925	965	1005
<b>Default Cool CFM</b>																		
Low	75	90	115	135	160	185	205	225	250	190	220	255	290	325	360	395	430	460
Medium-Low	100	120	145	165	185	205	230	255	280	250	285	325	360	390	420	455	485	520
Medium-High	135	155	175	200	230	260	280	305	330	355	395	435	475	510	545	580	620	660
High	170	195	225	255	290	320	350	375	405	475	515	565	610	655	705	745	785	825
<b>Decrease (-10%) Cool CFM</b>																		
Low	55	70	90	110	135	155	175	195	220	150	170	200	225	255	285	315	340	370
Medium-Low	65	80	105	130	150	170	195	215	240	165	195	230	265	300	330	360	390	420
Medium-High	100	125	150	180	200	220	240	260	280	240	280	320	360	400	435	470	505	540
High	140	160	180	200	230	260	285	305	330	350	385	420	455	500	540	575	610	645

**TABLE 29**  
**G71MPP-60D-135 BLOWER PERFORMANCE** (less filter)  
**Bottom Return Air, Return Air from Both Sides or Return Air from Bottom and One Side**  
**0 through 0.80 in. w.g. External Static Pressure Range**

<b>HEATING BLOWER PERFORMANCE</b>							
Heating Adjust CFM Selections	Heating Input Range and Blower Volume - CFM						
	40%	50%	60%	70%	80%	90%	100%
Increase (+15%) Heat CFM	1045	1220	1390	1565	1725	1885	2045
Increase (+7.5%) Heat CFM	975	1130	1290	1450	1600	1750	1900
Default Heat CFM	900	1045	1195	1340	1495	1650	1805
Decrease (-7.5%) Heat CFM	840	975	1110	1250	1390	1535	1675
Decrease (-15%) Heat CFM	760	890	1020	1145	1275	1405	1535

<b>COOLING BLOWER PERFORMANCE</b>								
Cooling Adjust CFM Selections	Blower Speed Selections							
	First Stage Cool Speed - cfm				Second Stage Cool Speed - cfm			
	Low	Medium-Low	Medium High	High (Default)	Low	Medium-Low	Medium High	High (Default)
Increase (+10%) Cool CFM	1135	1205	1365	1540	1615	1730	1945	2190
Default Cool CFM	1025	1105	1235	1390	1455	1580	1780	1985
Decrease (-10%) Cool CFM	915	985	1115	1235	1305	1400	1600	1780

The effect of static pressure is included in air volumes shown.

Lennox Harmony III™ Zone Control Applications - Minimum blower speed is 475 cfm.

The following control configurations are available. See Installation Instructions for details and DIP switch settings.

**Heat Mode** (Heating Blower Performance Table):

With a single-stage thermostat, furnace will operate at three, staged rates (40/70/100%) with a time delay between each stage (values in grey-shaded columns).

With two-stage thermostat there are two modes available.

Traditional two-stage mode - W1 demand results in 70% firing rate. W2 results in 100% firing rate. No delay between stages. (values shown in 70% and 100% grey-shaded columns only).

Variable Rate Capacity Mode - furnace automatically adjusts firing rate based on first- and second-stage cycle times. (all columns)

**Cool Mode** (Cooling Blower Performance table):

First stage COOL (two-stage air conditioning units only) is approximately 70% of the same second stage COOL speed position.

Continuous Fan speeds are approximately 28%, 38%, 70% and 100% (DIP switch selectable) of the same second-stage COOL speed position minimum 450 cfm.

**G71MPP-60D-135 BLOWER MOTOR WATTS - COOLING**  
**Bottom Return Air, Return Air from Both Sides or Return Air from Bottom and One Side**

Blower Speed Options	Motor Watts @ Various External Static Pressures - in. wg.																	
	First Stage									Second Stage								
	0	0.10	0.20	0.30	0.40	0.50	0.60	0.70	0.80	0	0.10	0.20	0.30	0.40	0.50	0.60	0.70	0.80
<b>Increase (+10%) Cool CFM</b>																		
Low	95	120	145	170	190	215	240	265	290	250	285	320	360	390	420	450	485	515
Medium-Low	115	135	160	185	210	235	260	290	315	290	330	375	420	455	490	525	565	605
Medium-High	145	175	215	250	275	300	330	355	385	425	465	505	550	590	635	670	710	750
High	205	240	280	320	350	380	410	445	480	615	655	700	745	800	855	900	940	980
<b>Default Cool CFM</b>																		
Low	80	95	115	135	160	190	210	230	255	185	215	245	280	310	335	370	400	430
Medium-Low	90	115	140	165	190	215	230	250	265	230	260	295	335	370	405	435	470	500
Medium-High	130	150	170	195	225	255	275	300	320	315	355	400	445	480	515	555	590	625
High	150	180	220	255	285	315	345	375	405	445	485	530	580	625	670	705	740	775
<b>Decrease (-10%) Cool CFM</b>																		
Low	65	80	100	120	140	160	180	195	215	145	170	195	225	250	280	305	330	355
Medium-Low	70	90	110	130	155	175	200	220	240	160	190	225	255	285	315	345	380	415
Medium-High	95	120	145	170	190	215	235	250	270	245	280	315	355	385	415	445	480	515
High	135	155	175	200	220	245	270	300	325	325	365	405	445	485	520	550	580	610

**TABLE 30**  
**G71MPP-60D-135 BLOWER PERFORMANCE (less filter) -- Single Side Return Air**  
(Air volumes in bold require field fabricated transition to accommodate 20 x 25 x 1 in. cleanable air filter in order to maintain proper air velocity across the filter.)  
**0 through 0.80 in. w.g. External Static Pressure Range**

**HEATING BLOWER PERFORMANCE**

Heating Adjust CFM Selections	Heating Input Range and Blower Volume - CFM						
	40%	50%	60%	70%	80%	90%	100%
Increase (+15%) Heat CFM	995	1160	1325	1490	1640	1790	<b>1940</b>
Increase (+7.5%) Heat CFM	930	1075	1225	1370	1520	1670	<b>1825</b>
Default Heat CFM	865	1005	1145	1280	1425	1570	1715
Decrease (-7.5%) Heat CFM	805	930	1060	1185	1325	1470	1610
Decrease (-15%) Heat CFM	735	850	970	1090	1215	1345	1470

**COOLING BLOWER PERFORMANCE**

Cooling Adjust CFM Selections	Blower Speed Selections							
	First Stage Cool Speed - cfm				Second Stage Cool Speed - cfm			
	Low	Medium-Low	Medium High	High (Default)	Low	Medium-Low	Medium High	High (Default)
Increase (+10%) Cool CFM	1105	1180	1330	1500	1585	1705	<b>1905</b>	<b>2130</b>
Default Cool CFM	990	1075	1210	1355	1430	1545	1765	<b>1975</b>
Decrease (-10%) Cool CFM	890	950	1085	1210	1275	1370	1565	1755

The effect of static pressure is included in air volumes shown.

Lennox Harmony III™ Zone Control Applications - Minimum blower speed is 475 cfm.

The following control configurations are available. See Installation Instructions for details and DIP switch settings.

**Heat Mode** (Heating Blower Performance Table):

With a single-stage thermostat, furnace will operate at three, staged rates (40/70/100%) with a time delay between each stage (values in grey-shaded columns).

With two-stage thermostat there are two modes available.

Traditional two-stage mode - W1 demand results in 70% firing rate. W2 results in 100% firing rate. No delay between stages. (values shown in 70% and 100% grey-shaded columns only).

Variable Rate Capacity Mode - furnace automatically adjusts firing rate based on first- and second-stage cycle times. (all columns)

**Cool Mode** (Cooling Blower Performance table):

First stage COOL (two-stage air conditioning units only) is approximately 70% of the same second stage COOL speed position.

Continuous Fan speeds are approximately 28%, 38%, 70% and 100% (DIP switch selectable) of the same second-stage COOL speed position minimum 450 cfm.

**G71MPP-60D-135 BLOWER MOTOR WATTS - COOLING**

Blower Speed Options	Motor Watts @ Various External Static Pressures - in. wg.																	
	First Stage									Second Stage								
	0	0.10	0.20	0.30	0.40	0.50	0.60	0.70	0.80	0	0.10	0.20	0.30	0.40	0.50	0.60	0.70	0.80
<b>Increase (+10%) Cool CFM</b>																		
Low	90	110	140	170	195	220	240	265	290	230	265	310	355	390	425	460	490	525
Medium-Low	105	130	165	195	215	235	260	290	315	285	330	380	430	455	485	525	565	605
Medium-High	150	175	205	235	270	300	330	360	385	425	465	515	560	605	645	685	730	770
High	195	230	270	305	340	375	410	445	480	605	650	695	740	800	855	900	945	985
<b>Default Cool CFM</b>																		
Low	70	90	115	135	165	190	210	230	245	170	200	235	265	305	345	380	420	455
Medium-Low	80	100	130	160	185	210	230	255	275	245	270	305	335	370	410	440	470	505
Medium-High	120	140	170	195	225	255	280	305	330	350	385	420	455	495	530	570	610	645
High	145	175	215	250	280	315	345	375	410	455	500	555	605	645	680	725	770	810
<b>Decrease (-10%) Cool CFM</b>																		
Low	60	75	95	115	135	150	175	195	220	140	160	185	205	240	280	305	335	360
Medium-Low	60	75	100	125	150	175	195	215	235	145	180	215	250	290	325	355	385	420
Medium-High	90	110	140	165	190	215	235	255	270	230	265	305	345	380	420	450	480	510
High	120	140	170	195	225	255	275	300	325	330	365	405	445	485	525	560	595	635

**TABLE 31**  
**G71MPP-60D-135 BLOWER PERFORMANCE (less filter) -- Side Return Air with Optional RAB Return Air Base**  
**0 through 0.80 in. w.g. External Static Pressure Range**

<b>HEATING BLOWER PERFORMANCE</b>							
Heating Adjust CFM Selections	Heating Input Range and Blower Volume - CFM						
	40%	50%	60%	70%	80%	90%	100%
Increase (+15%) Heat CFM	1020	1180	1340	1500	1650	1800	1955
Increase (+7.5%) Heat CFM	950	1095	1245	1395	1535	1680	1825
Default Heat CFM	885	1020	1160	1300	1435	1575	1715
Decrease (-7.5%) Heat CFM	820	945	1075	1200	1335	1475	1610
Decrease (-15%) Heat CFM	745	870	990	1110	1230	1350	1470

<b>COOLING BLOWER PERFORMANCE</b>								
Cooling Adjust CFM Selections	Blower Speed Selections							
	First Stage Cool Speed - cfm				Second Stage Cool Speed - cfm			
	Low	Medium-Low	Medium High	High (Default)	Low	Medium-Low	Medium High	High (Default)
Increase (+10%) Cool CFM	1080	1155	1310	1480	1550	1660	1875	2105
Default Cool CFM	985	1055	1190	1325	1400	1510	1720	1920
Decrease (-10%) Cool CFM	875	945	1060	1190	1250	1345	1530	1715

The effect of static pressure is included in air volumes shown.  
 Lennox Harmony III™ Zone Control Applications - Minimum blower speed is 475 cfm.  
 The following control configurations are available. See Installation Instructions for details and DIP switch settings.  
**Heat Mode** (Heating Blower Performance Table):  
 With a single-stage thermostat, furnace will operate at three, staged rates (40/70/100%) with a time delay between each stage (values in grey-shaded columns).  
 With two-stage thermostat there are two modes available.  
 Traditional two-stage mode - W1 demand results in 70% firing rate. W2 results in 100% firing rate. No delay between stages. (values shown in 70% and 100% grey-shaded columns only).  
 Variable Rate Capacity Mode - furnace automatically adjusts firing rate based on first- and second-stage cycle times. (all columns)  
**Cool Mode** (Cooling Blower Performance table):  
 First stage COOL (two-stage air conditioning units only) is approximately 70% of the same second stage COOL speed position.  
 Continuous Fan speeds are approximately 28%, 38%, 70% and 100% (DIP switch selectable) of the same second-stage COOL speed position minimum 450 cfm.

**G71MPP-60D-135 BLOWER MOTOR WATTS - COOLING - Side Return Air with Optional RAB Return Air Base**

Blower Speed Options	Motor Watts @ Various External Static Pressures - in. wg.																	
	First Stage									Second Stage								
	0	0.10	0.20	0.30	0.40	0.50	0.60	0.70	0.80	0	0.10	0.20	0.30	0.40	0.50	0.60	0.70	0.80
<b>Increase (+10%) Cool CFM</b>																		
Low	90	110	140	165	190	210	235	260	285	235	265	305	340	380	415	450	480	515
Medium-Low	105	130	160	190	210	230	255	285	310	290	325	370	410	450	490	515	545	575
Medium-High	145	170	205	235	265	290	325	355	390	420	460	510	555	595	640	680	715	755
High	200	230	270	305	345	385	415	445	480	580	630	690	745	800	850	895	935	975
<b>Default Cool CFM</b>																		
Low	70	90	115	140	165	190	210	230	250	170	200	235	270	305	335	370	400	430
Medium-Low	90	105	125	150	175	200	225	250	270	200	230	270	310	355	400	435	465	495
Medium-High	115	140	170	195	225	250	275	300	325	330	365	400	440	485	525	555	585	615
High	145	175	205	240	270	295	330	365	395	435	480	530	580	625	675	715	750	790
<b>Decrease (-10%) Cool CFM</b>																		
Low	60	75	95	115	135	155	175	195	215	135	155	180	205	240	280	305	330	355
Medium-Low	70	90	110	130	150	170	195	215	235	160	185	215	240	275	310	345	375	410
Medium-High	85	105	130	155	180	205	230	250	270	220	255	295	335	370	410	440	475	510
High	120	140	170	195	220	240	270	295	325	330	365	400	440	480	525	555	585	615

## Unit Start-Up

FOR YOUR SAFETY READ BEFORE OPERATING

### ⚠ WARNING

Do not use this furnace if any part has been underwater. A flood-damaged furnace is extremely dangerous. Attempts to use the furnace can result in fire or explosion. Immediately call a qualified service technician to inspect the furnace and to replace all gas controls, control system parts, and electrical parts that have been wet or to replace the furnace, if deemed necessary.

### ⚠ WARNING



Danger of explosion. Can cause injury or product or property damage. Should the gas supply fail to shut off or if overheating occurs, shut off the gas valve to the furnace before shutting off the electrical supply.

### ⚠ CAUTION

Before attempting to perform any service or maintenance, turn the electrical power to unit OFF at disconnect switch.

### ⚠ WARNING

During blower operation, the ECM motor emits energy that may interfere with pacemaker operation. Interference is reduced by both the sheet metal cabinet and distance.

#### Priming Condensate Trap

The condensate trap should be primed with water prior to start-up to ensure proper condensate drainage. Either pour 10 fl. oz. (300 ml) of water into the trap, or follow these steps to prime the trap:

- 1 - Follow the lighting instructions to place the unit into operation.
- 2 - Set the thermostat to initiate a heating demand.
- 3 - Allow the burners to fire for approximately 3 minutes.
- 4 - Adjust the thermostat to deactivate the heating demand.
- 5 - Wait for the combustion air inducer to stop. Set the thermostat to initiate a heating demand and again allow the burners to fire for approximately 3 minutes.
- 6 - Adjust the thermostat to deactivate the heating demand and again wait for the combustion air inducer to stop. At this point, the trap should be primed with sufficient water to ensure proper condensate drain operation.

**BEFORE BEFORE PLACING THE UNIT INTO OPERATION**, smell all around the furnace area for gas. Be sure to smell next to the floor because some gas is heavier than air and will settle on the floor.

The gas valve on the G71MPP is equipped with a gas control switch. Use only your hand to move the control switch. Never use tools. If the switch will not move by hand, do not try to repair it. Force or attempted repair may result in a fire or explosion.

#### Placing the furnace into operation:

G71MPP units are equipped with an automatic ignition system. Do not attempt to manually light burners on this furnace. Each time the thermostat calls for heat, the burners will automatically light. The ignitor does not get hot when there is no call for heat on units with this ignition system.

### ⚠ WARNING

If you do not follow these instructions exactly, a fire or explosion may result causing property damage, personal injury or death.

#### Gas Valve Operation (Figure 48)

- 1 - **STOP!** Read the safety information at the beginning of this section.
- 2 - Set the thermostat to the lowest setting.
- 3 - Turn off all electrical power to the unit.
- 4 - This furnace is equipped with an ignition device which automatically lights the burners. Do **not** try to light the burners by hand.
- 5 - Remove the upper access panel.
- 6 - Move the gas valve switch to the **OFF** position. See figure 48.
- 7 - Wait five minutes to clear out any gas. If you then smell gas, **STOP!** Immediately call the gas supplier from a neighbor's phone. Follow the gas supplier's instructions. If you do not smell gas go to next step.
- 8 - Move gas valve switch to the **ON** position. See figure 48. Do not force.

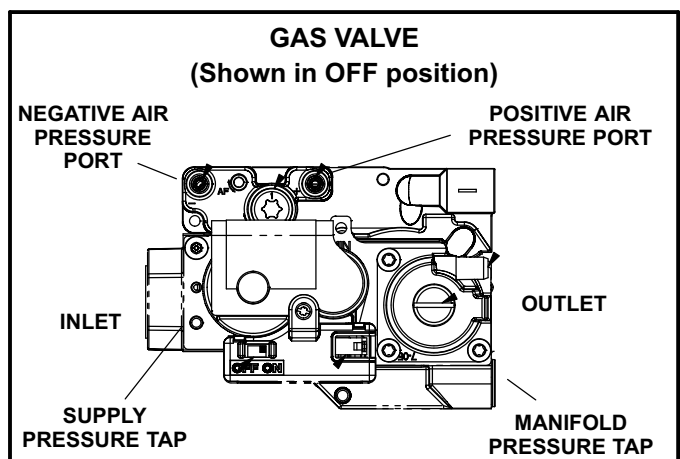


FIGURE 48



- 9 - Replace the upper access panel.
- 10- Turn on all electrical power to to the unit.
- 11- Set the thermostat to desired setting.

**NOTE** - When unit is initially started, steps 1 through 11 may need to be repeated to purge air from gas line.

- 12- If the appliance will not operate, follow the instructions "Turning Off Gas to Unit" and call the gas supplier.

#### Turning Off Gas to Unit

- 1 - Set the thermostat to the lowest setting.
- 2 - Turn off all electrical power to the unit if service is to be performed.
- 3 - Remove the upper access panel.
- 4 - Move the gas valve switch to the **OFF** position.
- 5 - Replace the upper access panel.

### Gas Pressure Measurement

#### Gas Flow (Approximate)

**TABLE 32**

Gas Flow Rate (Ft. <sup>3</sup> /Hr.)		
Seconds for 1 Revolution	Gas Meter Size	
	1/2 cu ft Dial	1 cu ft Dial
10	180	360
12	150	300
14	129	257
16	113	225
18	100	200
20	90	180
22	82	164
24	75	150
26	69	138
28	64	129
30	60	120
32	56	113
34	53	106
36	50	100
38	47	95
40	45	90
42	43	86
44	41	82
46	39	78
48	38	75
50	36	72
52	35	69
54	33	67
56	32	64
58	31	62
60	30	60

- 1 - Operate unit at least 15 minutes before checking gas flow. Determine the time in seconds for one revolutions of gas through the meter.
- 2 - Compare the number of seconds and the gas meter size in table 32 to determine the gas flow rate. Multiply the gas flow rate by the heating value to determine the unit input rate. If manifold pressure is correct and the unit input rate is incorrect, check gas orifices for proper size and restriction.
- 3 - Remove temporary gas meter if installed.

**NOTE** - To obtain accurate reading, shut off all other gas appliances connected to meter.

#### Supply Pressure Measurement

A threaded plug on the inlet side of the gas valve provides access to the supply pressure tap. Remove the threaded plug, install a field-provided barbed fitting and connect a manometer to measure supply pressure. Replace the threaded plug after measurements have been taken.

#### Manifold Pressure Measurement (Figure 49)

To correctly measure manifold pressure, the differential pressure between the positive gas manifold and the negative burner box must be considered. Use pressure test adapter kit (available as Lennox part 10L34) to assist in measurement.

- 1 - Remove the threaded plug from the outlet side of the gas valve and install a field-provided barbed fitting. Connect measuring device "+" connection to barbed fitting to measure manifold pressure.
- 2 - Tee into the gas valve regulator vent hose and connect measuring device "-" connection.
- 3 - Start unit on low heat (40% rate) and allow 5 minutes for unit to reach steady state.
- 4 - While waiting for the unit to stabilize, notice the flame. Flame should be stable and should not lift from burner. Natural gas should burn blue.
- 5 - After allowing unit to stabilize for 5 minutes, record manifold pressure and compare to value given in table 34.
- 6 - Repeat steps 3, 4 and 5 on high heat.

**NOTE** - Shut unit off and remove manometer as soon as an accurate reading has been obtained. Take care to remove barbed fitting and replace threaded plug.

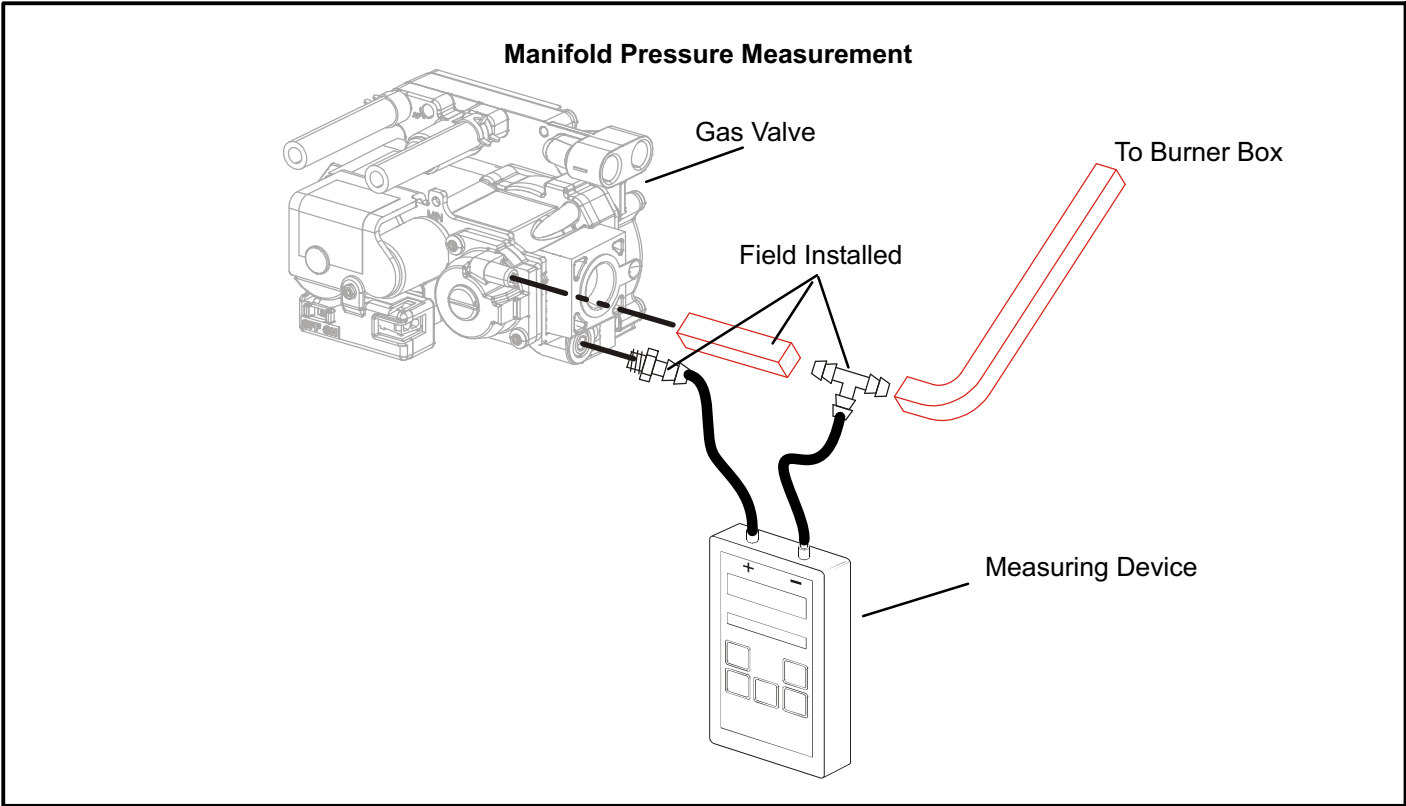
### **⚠ CAUTION**

**Do not attempt to make adjustments to the gas valve.**

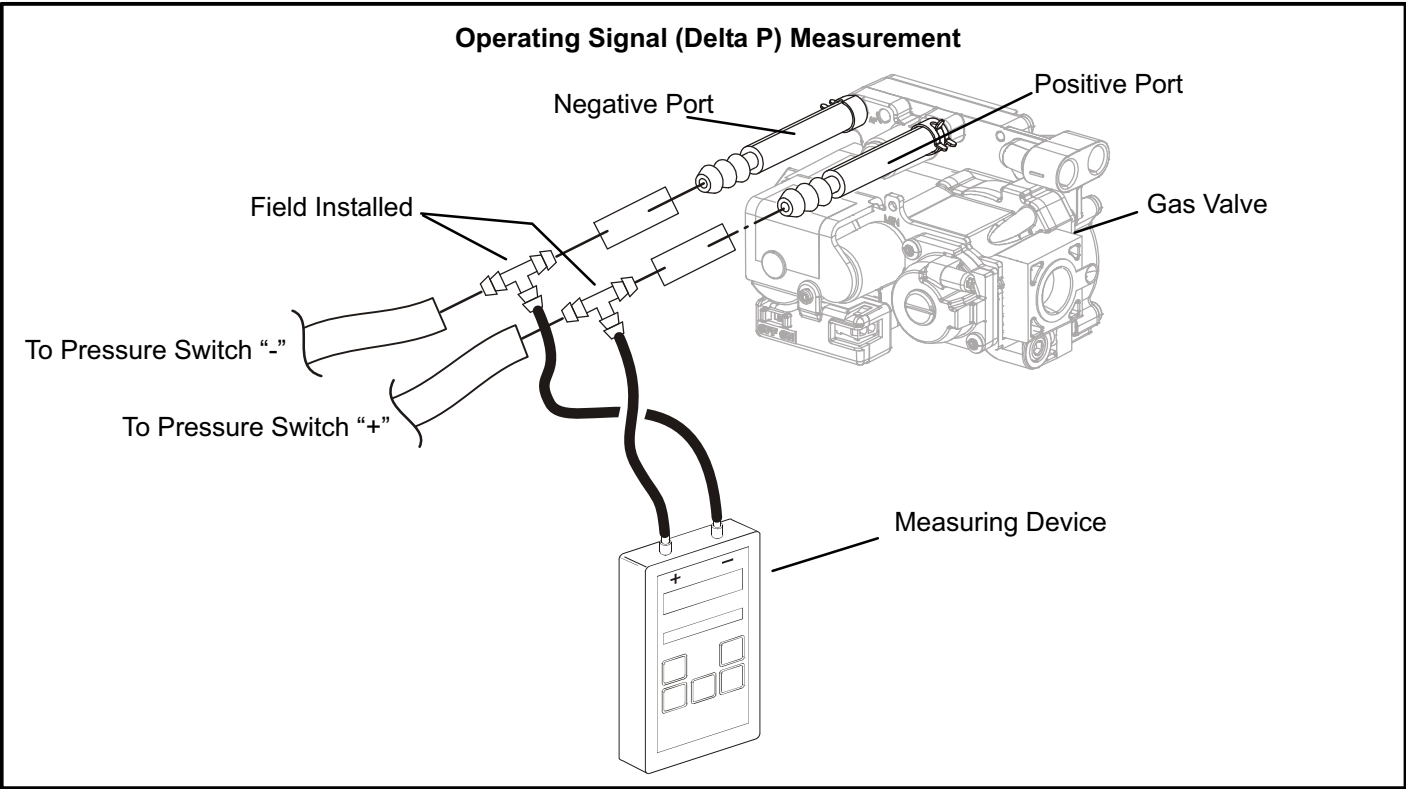
#### Operating Pressure Signal (Delta P) Measurement (Figure 50)

Operating pressure signal can be taken while the manifold pressure check is taken (using two measuring devices). Or, taken after the manifold pressure measurement is complete.

- 1 - Tee into the negative line between the gas valve and pressure switch and connect to measuring device negative "-".
- 2 - Tee into the positive line between the gas valve and pressure switch and connect to measuring device positive "+".
- 3 - Start unit on low heat (40% rate) and allow 5 minutes for unit to reach steady state.
- 4 - After allowing unit to stabilize for 5 minutes, record operating pressure signal and compare to value given in table 34.
- 5 - Repeat steps 3 on 4 high heat.



**FIGURE 49**



**FIGURE 50**

## High Altitude Information

**NOTE** - In Canada, certification for installations at elevations over 4500 feet (1372 m) is the jurisdiction of local authorities.

G71MPP units require no manifold pressure adjustments for operation at altitudes up to 10,000 feet (3048m) above sea level. Units installed at altitude of 7,501 to 10,000 feet (2287 to 3048m) require a pressure switch change per table 33. See table 33 for pressure switch and gas conversion requirements. Table 34 shows manifold pressures at varying altitudes.

**NOTE** - The values given in table 34 are measurements only. The gas valve should not be adjusted.

**TABLE 33**  
**Conversion Kit Requirements**

Model Input Size	LP/Propane Kit	High Altitude Pressure Switch Kit	
	0 - 10,000 (0 - 3048 m)	0 - 7,500 (0 - 2286 m)	7,501 - 10,000 (2287 - 3048m)
-070	33W41	Not required	36W77
-090			40W05
-110			40W06
-135			40W07

**NOTE** - Pressure switch is factory set. No adjustment necessary. All models use the factory installed pressure switch from 0-7,500 feet (0- 2286m).

**TABLE 34**  
**Manifold and Operating Signal Pressures in inches 0 - 7500 ft (0 - 2286 m)**

G71MPP Firing Rate	Manifold Pressure Nat Gas			Manifold Pressure LP/Propane			Operating Pressure Signal (Delta P)		
	Min	Normal	Max	Min	Normal	Max	Min	Normal	Max
40%	0.5	0.7	0.9	1.7	2.0	2.3	0.27	0.32	0.37
70%	1.7	1.9	2.1	5.1	5.5	5.9	0.55	0.60	0.65
100%	3.2	3.5	3.8	9.5	10.0	10.5	0.95	1.00	1.05

## Other Unit Adjustments

### Primary and Secondary Limits

The primary limit is located on the heating compartment vestibule panel. The secondary limits are located in the blower compartment, attached to the back side of the blower. These limits are factory set and require no adjustment.

### Flame Rollout Switches (Two)

These manually reset switches are located on the burner box. If tripped, check for adequate combustion air before resetting.

### Pressure Switches (Three)

The pressure switches are located in the heating compartment on the combustion air inducer. These switches check for proper combustion air inducer operation before allowing ignition trial. The switches are factory-set and require no adjustment.

### Back-Up Secondary Limit (090, 110 and 135)

The back-up secondary limit is located on the combustion air inducer. This switch protects the plastic components from overheating due to indoor blower motor failure. If tripped, check for proper blower operation before resetting.

### Temperature Rise

After the furnace has been started and supply and return air temperatures have been allowed to stabilize, check the temperature rise with the unit operating at 100 percent firing rate. If necessary, adjust the blower speed to maintain the temperature rise within the range shown on the unit nameplate. Increase the blower speed to decrease the temperature. Decrease the blower speed to increase the temperature rise. Failure to adjust the temperature rise may cause erratic limit operation.

### Thermostat Heat Anticipation

Set the heat anticipator setting (if adjustable) according to the amp draw listed on the wiring diagram that is attached to the unit.

### Electrical

- 1 - Check all wiring for loose connections.
- 2 - Check for the correct voltage at the furnace (furnace operating).
- 3 - Check amp-draw on the blower motor.  
Motor Nameplate \_\_\_\_\_ Actual \_\_\_\_\_

**NOTE** - Do not secure the electrical conduit directly to the air ducts or structure.

### Electronic Ignition

The integrated control has an added feature of an internal Watchguard control. The feature serves as an automatic reset device for ignition control lockout caused by ignition failure. This type of lockout is usually due to low gas line pressure. After one hour of continuous thermostat demand for heat, the Watchguard will break and remake thermostat demand to the furnace and automatically reset the control to begin the ignition sequence.

### Exhaust and Air Intake Pipe

- 1 - Check exhaust and air intake connections for tightness and to make sure there is no blockage.
- 2 - Are pressure switches closed? Obstructed exhaust pipe will cause unit to shut off at pressure switches. Check termination for blockages.
- 3 - Reset manual flame rollout switches on burner box cover.

## Failure To Operate

If the unit fails to operate, check the following:

- 1 - Is the thermostat calling for heat?
- 2 - Are access panels securely in place?
- 3 - Is the main disconnect switch closed?
- 4 - Is there a blown fuse?
- 5 - Is the filter dirty or plugged? Dirty or plugged filters will cause the limit control to shut the unit off.
- 6 - Is gas turned on at the meter?
- 7 - Is the manual main shut-off valve open?
- 8 - Is the internal manual shut-off valve open?
- 9 - Is the unit ignition system in lock out? If the unit locks out again, inspect the unit for blockages.
- 10 - Is blower harness connected to ignition control? Furnace will not operate unless harness is connected.

## Heating Sequence of Operation

The integrated control initiates a pressure switch calibration at the initial unit start-up on a call for heat. The ignition control will also initiate a calibration any time main power is turned off and back on and a heating demand is present. Additional calibrations may be initiated by the service technician during field test sequence. The following heating sequence of operation assumes completion of a successful calibration.

**NOTE** - The thermostat selection DIP switch on the integrated control is factory-set in the "TWO-STAGE" position.

### Applications Using a Two-Stage Thermostat

#### A - Heating Sequence -- Control Thermostat Selection DIP switch in "Two-Stage" Position (Factory Setting)

- 1 - On a call for heat, thermostat first-stage contacts close sending a signal to the integrated control. The integrated control runs a self-diagnostic program and checks high temperature limit switches for normally closed contacts and pressure switches for normally open contacts. The combustion air inducer is energized at ignition speed, which is approximately the same as the inducer speed at 70 percent firing rate.
- 2 - Once the control receives a signal that the low-fire pressure switch has closed, the combustion air inducer begins a 15-second pre-purge in the ignition speed.
- 3 - After the pre-purge is complete, a 20-second initial ignitor warm-up period begins. The combustion air inducer continues to operate at the ignition speed.
- 4 - After the 20-second warm-up period has ended, the gas valve is energized and ignition occurs. At the same time, the control module sends a signal to begin an indoor blower 45-second ON-delay. When the delay ends, the indoor blower motor is energized at a speed that matches the firing rate. After the 10-second ignition

stabilization delay expires, the inducer speed is adjusted to the appropriate target rate. The inducer will remain at the 70 percent speed as long as the thermostat has a first-stage heating demand.

- 5 - If second-stage heat is required, the thermostat second-stage heat contacts close and send a signal to the integrated control. The integrated control initiates a 30-second second-stage recognition delay.
- 6 - At the end of the recognition delay and on all subsequent calls for heat in the same heating cycle, the integrated control energizes the combustion air inducer at high speed. The control also checks the high-fire pressure switch to make sure it is closed. As the inducer speed is increased to high, the indoor blower motor is adjusted to a speed which is appropriate for the target rate.
- 7 - When the demand for high-fire (second stage) heat is satisfied, the gas valve is de-energized and the field-selected indoor blower off delay begins. The combustion air inducer begins a 20-second post-purge period.
- 8 - When the combustion air post-purge period is complete, the inducer is de-energized. The indoor blower is de-energized at the end of the off delay.

### Applications Using a Two-Stage Thermostat

#### B - Heating Sequence -- Control Thermostat Selection DIP switch in "Variable Capacity" Position

- 1 - On a call for heat, thermostat first-stage contacts close sending a signal to the integrated control. The integrated control runs a self-diagnostic program and checks high temperature limit switches for normally closed contacts and pressure switches for normally open contacts. The combustion air inducer is energized at ignition speed, which is approximately the same as the inducer speed at 70 percent firing rate.
- 2 - Once the control receives a signal that the low-fire pressure switch has closed, the combustion air inducer begins a 15-second pre-purge in low speed.
- 3 - After the pre-purge is complete, a 20-second initial ignitor warm-up period begins. The combustion air inducer continues to operate at the ignition speed.
- 4 - After the 20-second warm-up period has ended, the gas valve is energized and ignition occurs. At the same time, the control module begins an indoor blower 45-second ON-delay. When the delay ends, the indoor blower motor is energized at a speed that matches the firing rate. After the 10-second ignition stabilization delay expires, the inducer speed is adjusted to the appropriate target rate. If the furnace is operating in the initial heating cycle after power-up, the initial firing rate will be approximately 40 percent. The firing rate on subsequent cycles will be automatically adjusted by the integrated control based on thermostat cycles. The firing rate will vary and will range from 40 percent to 90 percent. The furnace will continue this operation as long as the thermostat has a first-stage heating demand.

- 5 - If second-stage heat is required, the thermostat second-stage heat contacts close and send a signal to the integrated control. The integrated control either increases the firing rate to 70 percent (if the current rate is at or below 60 percent) or increases the firing rate by 10 percent (if the current rate is above 60 percent). If the call for heat continues 5 minutes beyond this initial upstage, the rate will be increased by 10 percent every 5 minutes until the call for heat is satisfied or the furnace reaches 100 percent rate. As the firing rate increases, the indoor blower motor is adjusted to a speed which is appropriate for the target rate.
- 6 - If second-stage heat demand is satisfied, but first stage is still present, the furnace will continue to operate at the present firing rate until the heat cycle ends.
- 7 - When the demand for first- and second-stage heat is satisfied, the gas valve is de-energized and the field-selected indoor blower off delay begins. The combustion air inducer begins a 20-second post-purge period.
- 8 - When the combustion air post-purge period is complete, the inducer is de-energized. The indoor blower is de-energized at the end of the off delay.

#### Applications Using A Single-Stage Thermostat

#### C - Heating Sequence -- Control Thermostat Selection DIP switch in "Single-Stage" Position

- 1 - On a call for heat, thermostat first-stage contacts close sending a signal to the integrated control. The integrated control runs a self-diagnostic program and checks high temperature limit switches for normally closed contacts and pressure switches for normally open contacts. The combustion air inducer is energized at the ignition speed, which is approximately the same as the inducer speed at 70 percent firing rate.
- 2 - Once the control receives a signal that the low-fire pressure switch has closed, the combustion air inducer begins a 15-second pre-purge at the ignition speed.
- 3 - After the pre-purge is complete, a 20-second initial ignitor warm-up period begins. The combustion air inducer continues to operate at the ignition speed.
- 4 - After the 20-second warm-up period has ended, the gas valve is energized and ignition occurs, which initiates a 10-second ignition stabilization delay. At the same time, the control module sends a signal to begin an indoor blower 45-second ON-delay. When the delay ends, the indoor blower motor is energized at a speed which is appropriate for the firing rate. After the 10-second ignition stabilization delay expires, the inducer speed is adjusted to 40 percent speed. The integrated control also initiates a second-stage on delay (factory-set at 7 minutes; adjustable to 12 minutes).

- 5 - If the heating demand continues beyond the second-stage on delay, the integrated control energizes the combustion air inducer at 70 percent speed. The indoor blower motor is adjusted to a speed which matches the target rate. A fixed, 10-minute third-stage on delay is initiated.
- 6 - If the heating demand continues beyond the third-stage on delay, the integrated control energizes the inducer at high speed. The indoor blower motor is adjusted to a speed which is appropriate for the target rate.
- 7 -When the thermostat heating demand is satisfied, the gas valve is de-energized and the combustion air inducer begins a 20-second post-purge. The field-selected indoor blower off delay begins.
- 8 - When the combustion air post-purge period is complete, the inducer is de-energized. The indoor blower is de-energized at the end of the off delay.

### Service

**⚠ WARNING**

**ELECTRICAL SHOCK, FIRE, OR EXPLOSION HAZARD.**

**Failure to follow safety warnings exactly could result in dangerous operation, serious injury, death or property damage.**

**Improper servicing could result in dangerous operation, serious injury, death, or property damage.**

**Before servicing, disconnect all electrical power to furnace.**

**When servicing controls, label all wires prior to disconnecting. Take care to reconnect wires correctly.**

**Verify proper operation after servicing.**

At the beginning of each heating season, system should be checked as follows by a qualified service technician:

#### Blower

Check the blower wheel for debris and clean if necessary. The blower motors are prelubricated for extended bearing life. No further lubrication is needed.

**⚠ WARNING**

**The blower access panel must be securely in place when the blower and burners are operating. Gas fumes, which could contain carbon monoxide, can be drawn into living space resulting in personal injury or death.**

## Filters

All G71MPP filters are installed external to the unit. Filters should be inspected monthly. Clean or replace the filters when necessary to ensure proper furnace operation. Table 3 lists recommended filter sizes.

## Exhaust and air intake pipes

Check the exhaust and air intake pipes and all connections for tightness and to make sure there is no blockage.

*NOTE - After any heavy snow, ice or frozen fog event the furnace vent pipes may become restricted. Always check the vent system and remove any snow or ice that may be obstructing the plastic intake or exhaust pipes.*

## Electrical

- 1 - Check all wiring for loose connections.
- 2 - Check for the correct voltage at the furnace (furnace operating).
- 3 - Check amp-draw on the blower motor.  
Motor Nameplate \_\_\_\_\_ Actual \_\_\_\_\_

## Winterizing and Condensate Trap Care

- 1 - Turn off power to the unit.
- 2 - Have a shallow pan ready to empty condensate water.
- 3 - Remove the drain plug from the condensate trap and empty water. Inspect the trap then reinstall the drain plug and refill trap with water.

## Cleaning Heat Exchanger

If cleaning the heat exchanger becomes necessary, follow the below procedures and refer to figure 1 when disassembling unit. Use papers or protective covering in front of furnace while removing heat exchanger assembly.

- 1 - Turn off electrical and gas supplies to the furnace.
- 2 - Remove the upper and lower furnace access panels.
- 3 - Disconnect the 2-pin plug from the gas valve.
- 4 - Remove gas supply line connected to gas valve. Remove gas valve/manifold assembly.
- 5 - Remove sensor wire from sensor. Disconnect 2-pin plug from the ignitor.
- 6 - Disconnect wires from flame roll-out switches.
- 7 - Remove burner box cover and remove four burner box screws at the vestibule panel and remove burner box. Set burner box assembly aside.

***NOTE - G71MPP-135 units are secured to the vestibule panel by two additional screws. These screws must be removed for servicing; however it is not necessary to replace the screws.***

***NOTE - If necessary, clean burners at this time. Follow procedures outlined in Burner Cleaning section.***

- 8 - Loosen three clamps and remove flexible exhaust tee.
- 9 - Remove 3/8 inch rubber cap from condensate drain plug and drain. Replace cap after draining.

- 10 - Disconnect condensate drain line from the condensate trap. Remove condensate trap (it may be necessary to cut drain pipe). Remove screws that secure condensate collars to either side of the furnace and remove collars. Remove drain tubes from cold end header collector box.
- 11 - Disconnect condensate drain tubing from flue collar. Remove screws that secure both flue collars into place. Remove flue collars. It may be necessary to cut the exiting exhaust pipe for removal of the fittings.
- 12 - Mark and disconnect all combustion air pressure tubing from cold end header collector box.
- 13 - Mark and remove wires from pressure switches. Remove pressure switches. Keep tubing attached to pressure switches.
- 14 - Disconnect the 4-pin plug from the combustion air inducer. Disconnect the two wires to the backup secondary limit, if applicable. Remove four screws which secure combustion air inducer to collector box. Remove combustion air inducer assembly. Remove ground wire from vest panel.
- 15 - Remove electrical junction box from the side of the furnace.
- 16 - Mark and disconnect any remaining wiring to heating compartment components. Disengage strain relief bushing and pull wiring and bushing through the hole in the blower deck.
- 17 - Remove the primary limit from the vestibule panel.
- 18 - Remove two screws from the front cabinet flange at the blower deck. Spread cabinet sides slightly to allow clearance for removal of heat exchanger.
- 19 - Remove screws along vestibule sides and bottom which secure vestibule panel and heat exchanger assembly to cabinet. Remove two screws from blower rail which secure bottom heat exchanger flange. Remove heat exchanger from furnace cabinet.
- 20 - Back wash heat exchanger with soapy water solution or steam. **If steam is used it must be below 275°F (135°C) .**
- 21 - Thoroughly rinse and drain the heat exchanger. Soap solutions can be corrosive. Take care to rinse entire assembly.
- 22 - Reinstall heat exchanger into cabinet making sure that the clamshells of the heat exchanger assembly are resting on the support located at the rear of the cabinet. Remove the indoor blower to view this area through the blower opening.
- 23 - Re-secure the supporting screws along the vestibule sides and bottom to the cabinet.
- 24 - Reinstall cabinet screws on front flange at blower deck.
- 25 - Reinstall the primary limit on the vestibule panel.
- 26 - Route heating component wiring through hole in blower deck and reinsert strain relief bushing.
- 27 - Reinstall electrical junction box.

- 28 - Reinstall the combustion air inducer. Reconnect the 4-pin plug to the wire harness. Reconnect the two wires to the backup secondary limit, if applicable.
- 29 - Reinstall pressure switches and reconnect pressure switch wiring.
- 30 - Carefully connect combustion air pressure switch hosing from pressure switches to proper stubs on cold end header collector box.
- 31 - Reinstall condensate collars on each side of the furnace. Reconnect drain tubing to collector box.
- 32 - Reinstall condensate trap on same side as exhaust pipe. Reconnect condensate drain line to the condensate trap.
- 33 - Use securing screws to reinstall flue collars to either side of the furnace. Reconnect exhaust piping and exhaust drain tubing.
- 34 - Replace flexible exhaust tee on combustion air inducer and flue collars. Secure using three existing hose clamps.
- 35 - Reinstall burner box assembly in vestibule area.
- 36 - Reconnect flame roll-out switch wires.
- 37 - Reconnect sensor wire and reconnect 2-pin plug from ignitor.
- 38 - Secure burner box assembly to vestibule panel using four existing screws. **Make sure burners line up in center of burner ports.**
- 39 - Reinstall gas valve manifold assembly. Reconnect gas supply line to gas valve.
- 40 - Reinstall burner box cover.
- 41 - Reconnect 2-pin plug to gas valve.
- 42 - Replace the blower compartment access panel.
- 43 - Refer to instruction on verifying gas and electrical connections when re-establishing supplies.
- 44 - Follow lighting instructions to light and operate furnace for 5 minutes to ensure that heat exchanger is clean and dry and that furnace is operating properly.
- 45 - Replace heating compartment access panel.

#### **Cleaning the Burner Assembly**

- 1 - Turn off electrical and gas power supplies to furnace. Remove upper and lower furnace access panels.
- 2 - Disconnect the 2-pin plug from the gas valve.
- 3 - Disconnect the gas supply line from the gas valve. Remove gas valve/manifold assembly.
- 4 - Mark and disconnect sensor wire from the sensor. Disconnect 2-pin plug from the ignitor at the burner box.
- 5 - Remove burner box cover and remove four screws which secure burner box assembly to vest panel. Remove burner box from the unit.  
***NOTE** - G71MPP-135 units are secured to the vestibule panel by two additional screws. These screws must be removed for servicing; however it is not necessary to replace the screws.*
- 6 - Use the soft brush attachment on a vacuum cleaner to gently clean the face of the burners. Visually inspect the inside of the burners and crossovers for any blockage caused by foreign matter. Remove any blockage.

- 7 - Reconnect the sensor wire and reconnect the 2-pin plug to the ignitor wiring harness.
- 8 - Reinstall the burner box assembly using the existing four screws. Make sure that the burners line up in the center of the burner ports.
- 9 - Reinstall the gas valve manifold assembly. Reconnect the gas supply line to the gas valve. Reinstall the burner box cover.
- 10 - Reconnect 2-pin plug to gas valve.
- 11 - Replace the blower compartment access panel.
- 12 - Refer to instruction on verifying gas and electrical connections when re-establishing supplies.
- 13 - Follow lighting instructions to light and operate furnace for 5 minutes to ensure that heat exchanger is clean and dry and that furnace is operating properly.
- 14 - Replace heating compartment access panel.

#### **Planned Service**

A service technician should check the following items during an annual inspection. Power to the unit must be shut off for the service technician's safety.

**Fresh air grilles and louvers** (on the unit and in the room where the furnace is installed) - Must be open and unobstructed to provide combustion air.

**Burners** - Must be inspected for rust, dirt, or signs of water.

**Vent pipe** - Must be inspected for signs of water, cracked, damaged or sagging pipe, or disconnected joints.

**Unit appearance** - Must be inspected for rust, dirt, signs of water, burnt or damaged wires, or components.

**Blower access door** - Must be properly in place and provide a seal between the return air and the room where the furnace is installed.

**Return air duct** - Must be properly attached and provide an air seal to the unit.

**Operating performance** - Unit must be observed during operation to monitor proper performance of the unit and the vent system.

**Combustion gases** - Flue products must be analyzed and compared to the unit specifications.

Problems detected during the inspection may make it necessary to temporarily shut down the furnace until the items can be repaired or replaced.

**Instruct the homeowners to pay attention to their furnace.** Situations can arise between annual furnace inspections that may result in unsafe operation. For instance, items innocently stored next to the furnace may obstruct the combustion air supply. This could cause incomplete combustion and the production of carbon monoxide gas.



## Integrated Control Diagnostic Codes

Press the diagnostic push button and hold it to cycle through a menu of options. Every five seconds a new menu item will be displayed. Release the button when the desired mode is displayed.

When a solid "P" is displayed, the furnace capacity/ size is programmed.

When the solid "E" is displayed, the control enters the Error Code Recall mode. Error Code Recall mode menu options: No change (displaying error history) remains in Error Code Recall mode; solid "b" exits Error Code Recall mode; and solid "c" clears the error history. Must press button while flashing "c" is displayed to clear error codes.

When the solid "-" is displayed, the control enters the Field Test mode. Field Test mode menu options: Solid "C" starts pressure switch calibration; blinking "-" exits Field Test mode.

Code	Diagnostic Codes/Status of Equipment	Action Required to Clear and Recover
.	Idle mode (Decimal blinks at 1 Hertz -- 0.5 second ON, 0.5 second OFF).	
A	Cubic feet per minute (cfm) setting for indoor blower (1 second ON, 0.5 second OFF) / cfm setting for current mode displayed.	
C	Cooling stage (1 second ON, 0.5 second OFF) / 1 or 2 displayed / Pause / cfm setting displayed / Pause / Repeat codes).	
d	Dehumidification mode (1 second ON) / 1 second OFF) / cfm setting displayed / Pause / Repeat Codes).	
h	Variable Capacity Heat (1 second ON, 0.5 second OFF) / % of input rate displayed / Pause/ cfm setting / Pause/ Repeat codes.	
H	Heat Stage (1 second ON, 0.5 second OFF) / 1 or 2 displayed / Pause / cfm setting displayed / Pause / Repeat codes.	
df	Defrost mode.	
E 105	Device communication problem - No other devices on BUS (Communication system).	Equipment is unable to communicate. Check for mis wire and loose connections and check for a high voltage source of noise close to the system. (welder etc.).
E 110	Low line voltage.	Line Voltage low (Voltage lower than nameplate rating) Check voltage.
E 113	High line voltage.	Line Voltage High (Voltage higher than nameplate rating) Check voltage.
E 114	Line voltage frequency out-of-range.	No 60 hertz power (Check voltage and frequency).
E 115	Low 24V - Control will restart if the error recovers.	24 voltage low (Range is 18 to 30 volts) Check voltage.
E 120	Unresponsive device.	Usually caused by delay in outdoor unit responding to indoor unit polling recycle power, check wiring.
E 124	Active communicating thermostat signal missing for more than 3 minutes.	Equipment lost communication with the thermostat. Check connections and cycle power on the thermostat.
E 125	Control failed self-check, internal error, failed hardware. Will restart if error recovers. Integrated furnace control not communicating. Covers hardware errors (flame sense circuit faults, pin shorts, etc.).	Hardware problem on the control board. Cycle power on control. Replace if problem prevents service and is persistent.
E 126	Failed internal control communication between microcontrollers.	Hardware problem on the control board. Cycle power on control. Replace if problem prevents service and is persistent.
E 131	Corrupted control parameters (Verify configuration of system).	Reconfigure the system. Replace board if service (heating /cooling) is unavailable.
E 180	Outdoor air sensor failure - NO error if disconnected. Only shown if shorted or out-of-range.	Compare outdoor sensor resistance to temperature resistance charts in installation instructions. Replace if necessary.
E 200	Hard lockout - Rollout circuit open or previously open.	Correct unit cause of rollout trip or replace flame rollout switch and test furnace operation.
E 201	Indoor blower communication failure - Unable to communicate with blower motor.	Indoor blower communication failure including power outage.
E 202	Indoor blower motor mis-match - Indoor motor horsepower does not match unit capacity.	Incorrect furnace size code selected. Check unit size codes on configuration guide or in installation instructions.
E 203	Appliance capacity / size is NOT programmed. Invalid unit codes refer to configuration flow chart in installation instructions.	No furnace size code selected. Check unit size codes on configuration guide or in installation instructions.
E 204	Gas valve mis-wired.	Check operation of gas valve.
E 205	Gas valve control relay contact shorted.	Check operation of gas valve.
E 207	Hot surface ignitor sensed open - Refer to troubleshooting in installation instruction.	Measure resistance of Hot Surface Ignitor, replace if open or not within specification.

## Integrated Control Diagnostic Codes (continued)

Code	Diagnostic Codes/Status of Equipment	Action Required to Clear and Recover
E 223	Low pressure switch failed open - Refer to troubleshooting in installation instruction.	Check inches of water column pressure during operation of low pressure switch on heat call, measure inches of water column of operating pressure, inspect vent and combustion air inducer for correct operation and restriction.
E 224	Low pressure switch failed closed - Refer to troubleshooting in installation instruction.	Check low pressure switch for closed contacts, measure inches of water column of operating pressure, inspect vent and combustion air inducer for correct operation and restriction.
E 225	High pressure switch failed open - Refer to troubleshooting in installation instruction.	Check inches of water column pressure of high pressure switch on heat call, measure inches of water column of operating pressure, inspect vent and combustion air inducer for correct operation and restriction.
E 226	High pressure switch failed closed - Refer to troubleshooting in installation instruction.	Check high pressure switch for closed contacts, measure inches of water column of operating pressure, inspect vent and combustion air inducer for correct operation and restriction.
E 227	Low pressure switch open during trial for ignition or run mode. Refer to troubleshooting in installation instruction.	Check inches of water column pressure during operation of low pressure switch on heat call, measure inches of water column of operating pressure, inspect vent and combustion air inducer for correct operation and restriction.
E 228	Unable to perform successful pressure switch calibration.	Retry after 300 seconds. Error counter cleared when exiting lockout, unable to perform pressure switch calibration. Check vent system and pressure switch wiring connections.
E 240	Low flame current - Run mode - Refer to troubleshooting in installation instruction.	Check micro amperes of flame sensor, clean or replace sensor. Measure voltage of neutral to ground for good unit ground.
E 241	Flame sensed out of sequence - Flame still present.	Shut off gas, check for gas valve leak.
E 250	Limit switch circuit open - Refer to troubleshooting in installation instruction.	Check why limit is tripping, overfired, low air flow.
E 252	Discharge air temperature too high (gas heat only).	Check temperature rise, air flow and input rate.
E 270	Soft lockout - Exceeded maximum number of retries. No flame current sensed.	Check for gas flow, ignitor lighting burner, flame sensor current.
E 271	Soft lockout - Exceeded maximum number of retries. Last retry failed due to the pressure switch opening.	See E 223.
E 272	Soft lockout - Exceeded maximum number of recycles. Last recycle due to the pressure switch opening.	See E 223 and E 225.
E 273	Soft lockout - Exceeded maximum number of recycles. Last recycle due to flame failure.	See E 240.
E 274	Soft lockout - Exceeded maximum number of recycles. Last recycle failed due to the limit circuit opening or limit remained open longer than 3 minutes.	See E 250.
E 275	Soft lockout - Flame sensed out of sequence from code 241 fault. Flame signal is gone.	See E 241.
E 276	Soft lockout - Exceeded maximum number of calibration retries.	See E 228.
E 290	Ignitor circuit fault - Failed ignitor or triggering circuitry.	See E 207.
E 291	Restricted air flow - Cubic feet per minute is lower than what is needed for minimum firing rate.	Check for dirty filter, unit air flow restriction, blower performance.
E 292	Indoor blower motor unable to start - Seized bearings, stuck wheel, etc.	Indoor blower motor unable to start (seized bearing, stuck wheel, etc), replace motor or wheel if assembly does not operate or meet performance.
E 294	Combustion air inducer motor amp draw is too high.	Check combustion blower bearings, wiring, amperes, replace if it does not operate or meet performance.

## Integrated Control Diagnostic Codes (continued)

Code	Diagnostic Codes/Status of Equipment	Action Required to Clear and Recover
E 295	Indoor blower motor temperature is too high.	Indoor blower motor over temperature (motor tripped on internal protector), Check motor bearings, amperes. Replace if necessary.
E 310	Discharge error sensor failure - No error if disconnected. Only shown if shorted or out-of-range.	Discharge air temperature(DATS) out of range, code is activated during "Field test mode".
E 311	Heat rate reduced to match indoor blower air flow. Replace filter or repair duct restriction.	Furnace blower in cutback mode due to restricted airflow. Check filter and ductwork. To clear replace filter if needed or repair/ add ductwork.
E 312	Restricted air flow in cooling or continuous fan mode is lower than cfm setting.	Restricted airflow - Indoor blower is running at a reduced cubic feet per minute (Cutback Mode) - The variable speed motor has pre-set speed and torque limiters to protect the motor from damage caused by operating out of its designed parameters (0 to 0.8 inches water column total external static pressure). Check filter and ductwork. To clear replace filter if needed or repair/ add ductwork.
E 313	Indoor or outdoor unit capacity mismatch.	Incorrect Indoor /outdoor capacity code selected. Check for proper configuration in installation instructions. Alarm is just a warning. The system operation is not impacted at all and alarm would clear when Commissioning is exited.
E 331	Global network connection - Communication link problem.	For Future Use.
E 347	No 24 Volt output on Y1 to C with non-communicating outdoor unit.	Y1 relay / Stage 1 failed (Pilot relay contacts did not close or the relay coil did not energize).
E 348	No 24 Volt output on Y2 to C with non-communicating outdoor unit.	Y2 relay / Stage 2 failed (Pilot relay contacts did not close or the relay coil did not energize).
E 349	No 24 Volts between R & O with non-communicating outdoor unit (Dual fuel module required for heat pump application).	Configuration link R to O needs to be cut on control board.
E 401	LSOM - Compressor ran more than 18 hours in air conditioning mode.	Compressor protector is open. Check for high head pressure, check compressor supply voltage. Outdoor unit power disconnect is open , compressor circuit breaker or fuse(s) is open, broken wire or connector is not making contact. Low or high pressure switch open if present in the system. Compressor contactor has failed to close.
E 402	LSOM - Outdoor unit system pressure trip.	Compressor ran over 18 hours in air conditioning mode.
E 403	LSOM - Compressor short-cycling (Running less than 4 minutes).	Outdoor unit pressure trip. Check dirty coil, fan motor, refrigerant charge.
E 404	LSOM - Compressor rotor locked.	Compressor short cycling (Running less than 4 minutes).
E 405	LSOM - Compressor open circuit.	Check capacitor, wiring, hard start kit , replace compressor.
E 406	LSOM - Compressor open start circuit.	Check compressor for hot (cool down) , check pressures, fan motor etc. Replace compressor if unable to get circuit to close and compressor to operate.
E 407	LSOM - Compressor open run circuit.	
E 408	LSOM - Compressor contactor is welded.	
E 409	LSOM - Compressor low voltage.	Replace contactor.

# Configuring Unit Size Codes

**Power-up** - Unit Size Code number displayed represents unit size code (furnace model size and capacity). If three horizontal bars are display followed by continuous E203, Furnace control does not recognize **unit size code** (furnace model size and capacity).



Furnace control in **IDLE** mode  
(Decimal point blinking. No heating, cooling or indoor fan operation)

Yes

No

To enter **Field Test Mode**; Push and hold button next to 7-segment LED display until **solid dash** symbol appears, release button.



If alarm is present, furnace control will display error code, if alarm is not present **solid dash** starts blinking on 7-segment LED display



Push and hold button until the solid **P** symbol is displayed on the 7-segment LED, then release button. This mode allows the user to select a unit size code number that matches the furnace model size and capacity.



**IMPORTANT:** Field replacement controls may need to be manually configured to validate furnace unit size code.

Solid **P** starts blinking on 7-Segment LED



Push and hold button to allow furnace control to display unit size code number for each different furnace model for five seconds.

Turn room thermostat to **OFF**

UNIT SIZE CODE	FURNACE MODEL
0	G71MPP-36B-070
1	G71MPP-36C-090
2	G71MPP-60C-090
3	G71MPP-60C-110
4	G71MPP-60D-135

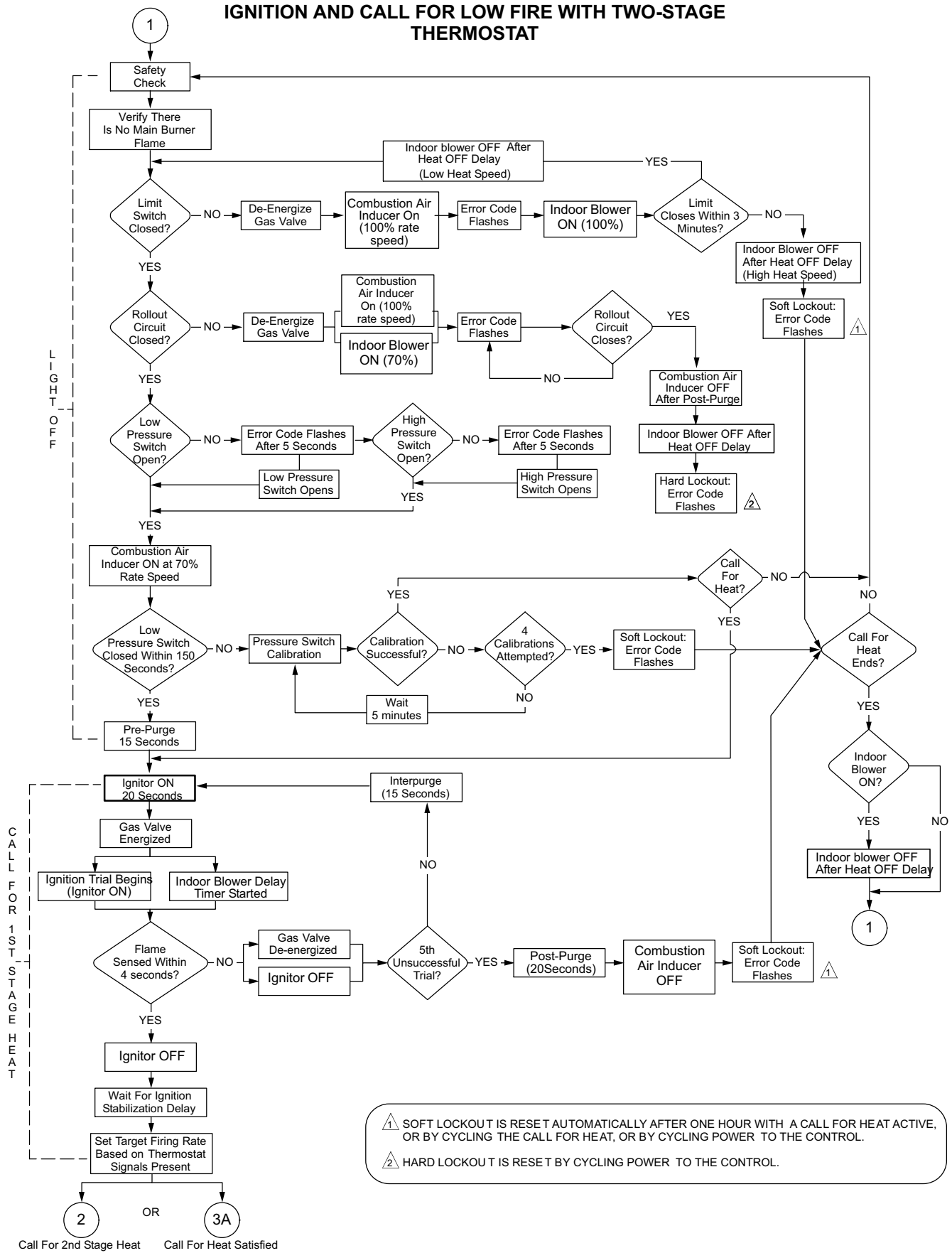
When the correct unit sized code is displayed, release button. Selected code will flash for 10 second period. During that period, hold push button until code stops blinking (disappear for 2 seconds). Furnace control will store code in memory and will automatically exit **Field Test Mode** and reset. (If second period expires or push button is held less than five seconds, control will automatically exit **Field Test Mode** and go into **IDLE** mode without storing unit size code. If this happens, configuring function must be repeated).

Verify that the selected unit size code is correct and stored in non-volatile memory by cycling the 24 volt power to the furnace control. (At 24 volt power-up of the IFC, the 7-segment LED will display a unit size code. If three horizontal bars display, board does not recognize **unit size code**. Programming function must be repeated)

**FINISHED**

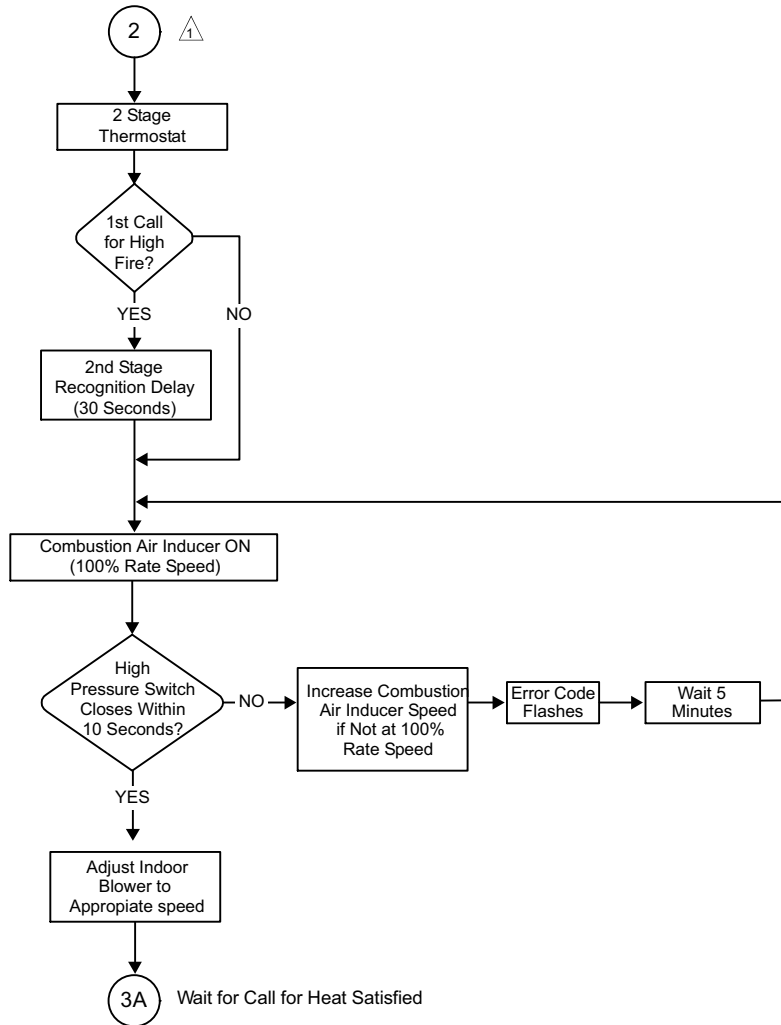
# Troubleshooting: Heating Sequence of Operation

## IGNITION AND CALL FOR LOW FIRE WITH TWO-STAGE THERMOSTAT



## Troubleshooting: Heating Sequence of Operation (Continued)

### CALL FOR HIGH FIRE WITH TWO-STAGE THERMOSTAT



⚠️ System will always light at 70% even if 2nd stage call for heat is in place

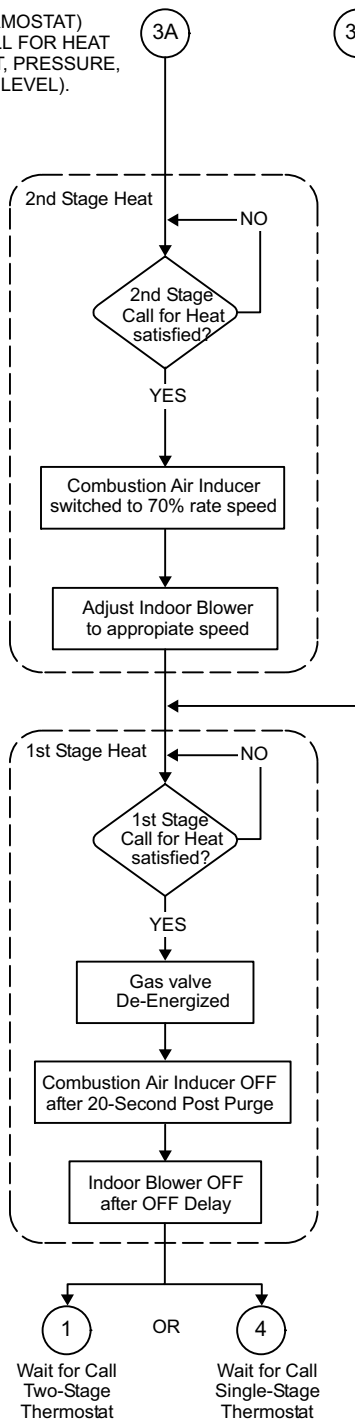
⚠️ If the high pressure switch does not close within 5 attempts, the system will operate at low fire for the remainder of the call for heat at request

# Troubleshooting: Heating Sequence of Operation (Continued)

## CALL FOR HEAT SATISFIED

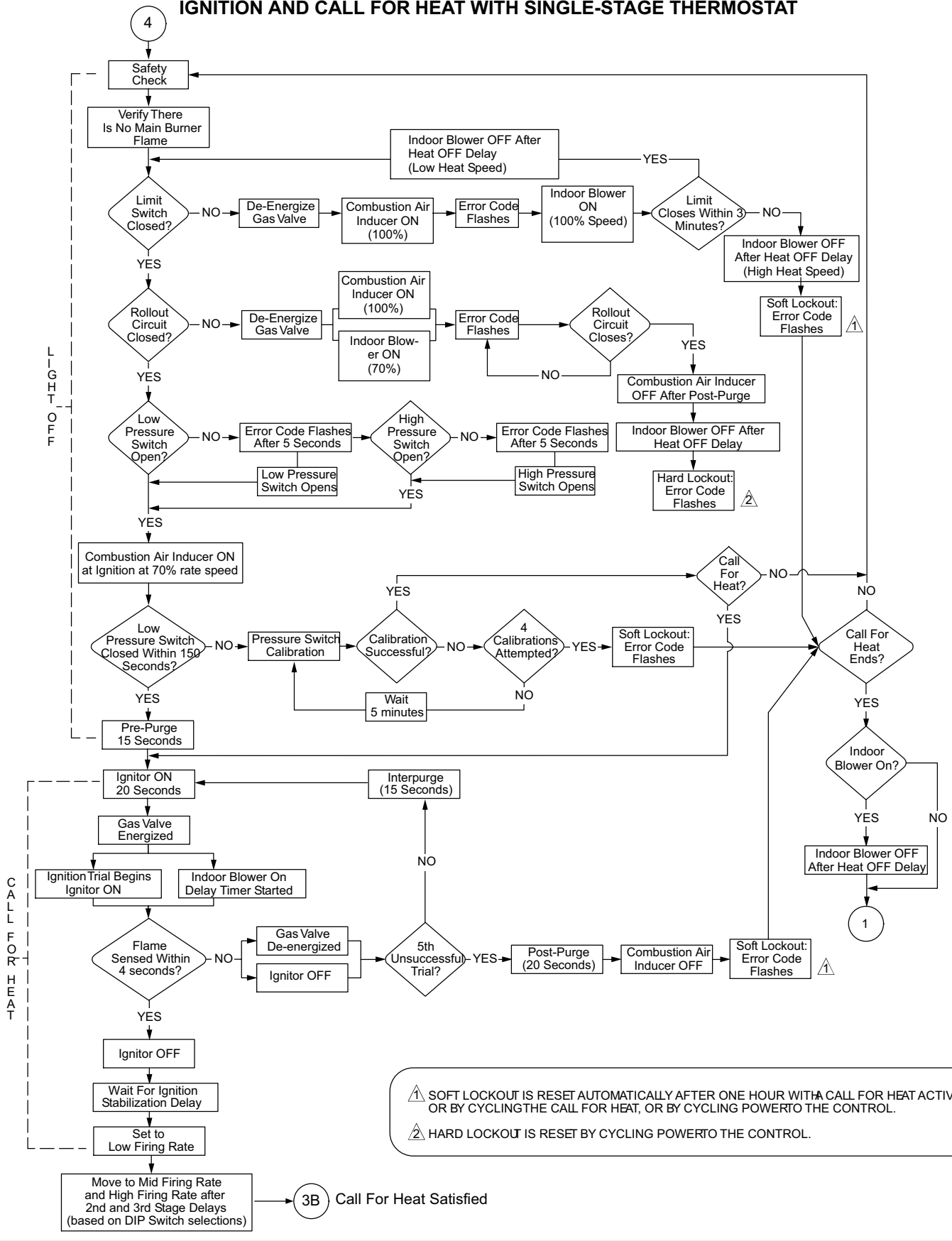
RUN MODE (TWO-STAGE THERMOSTAT)  
 FIRST OR SECOND-STAGE CALL FOR HEAT  
 ALL INPUTS MONITORED (LIMIT, PRESSURE,  
 CALL FOR HEAT/COOL, FLAME LEVEL).

RUN MODE (SINGLE-STAGE THERMOSTAT)  
 ALL INPUTS MONITORED (LIMIT, PRESSURE,  
 CALL FOR HEAT/COOL, FLAME LEVEL).



# Troubleshooting: Heating Sequence of Operation (Continued)

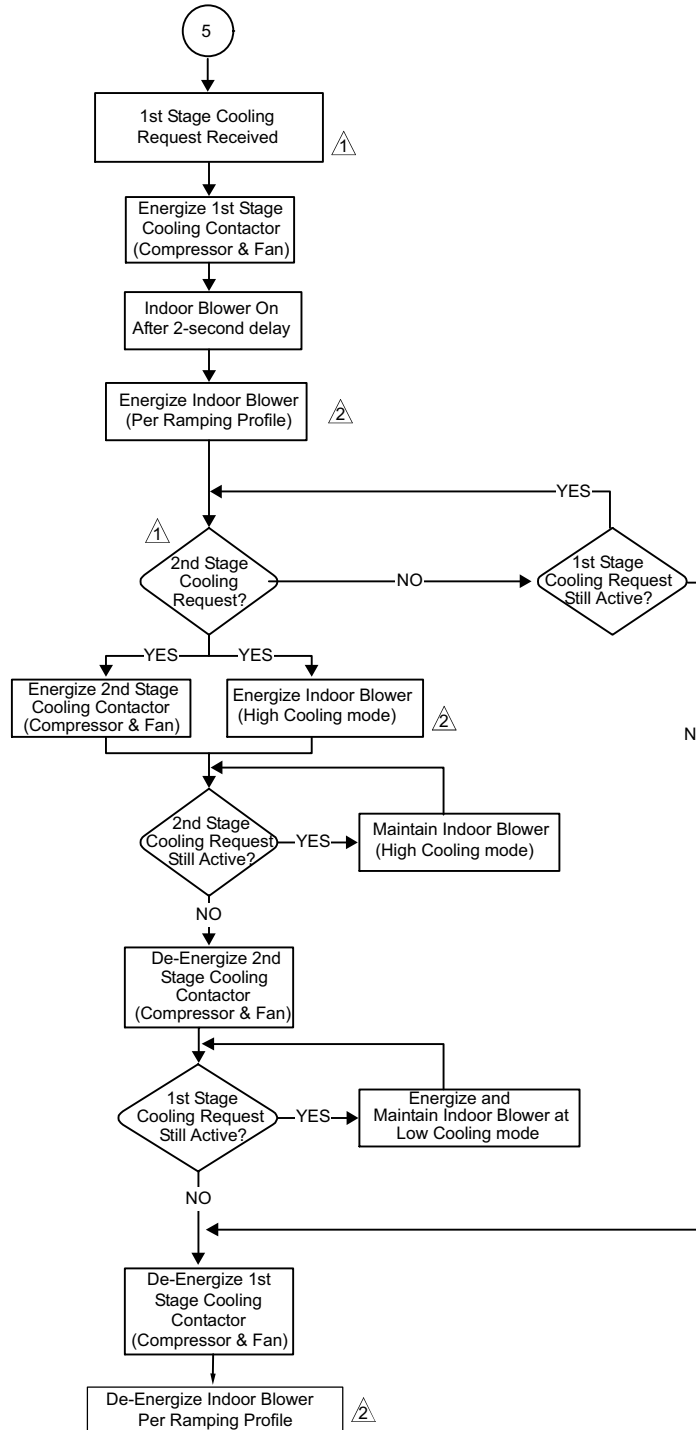
## IGNITION AND CALL FOR HEAT WITH SINGLE-STAGE THERMOSTAT





# Troubleshooting: Cooling Sequence of Operation

## CALL FOR COOLING

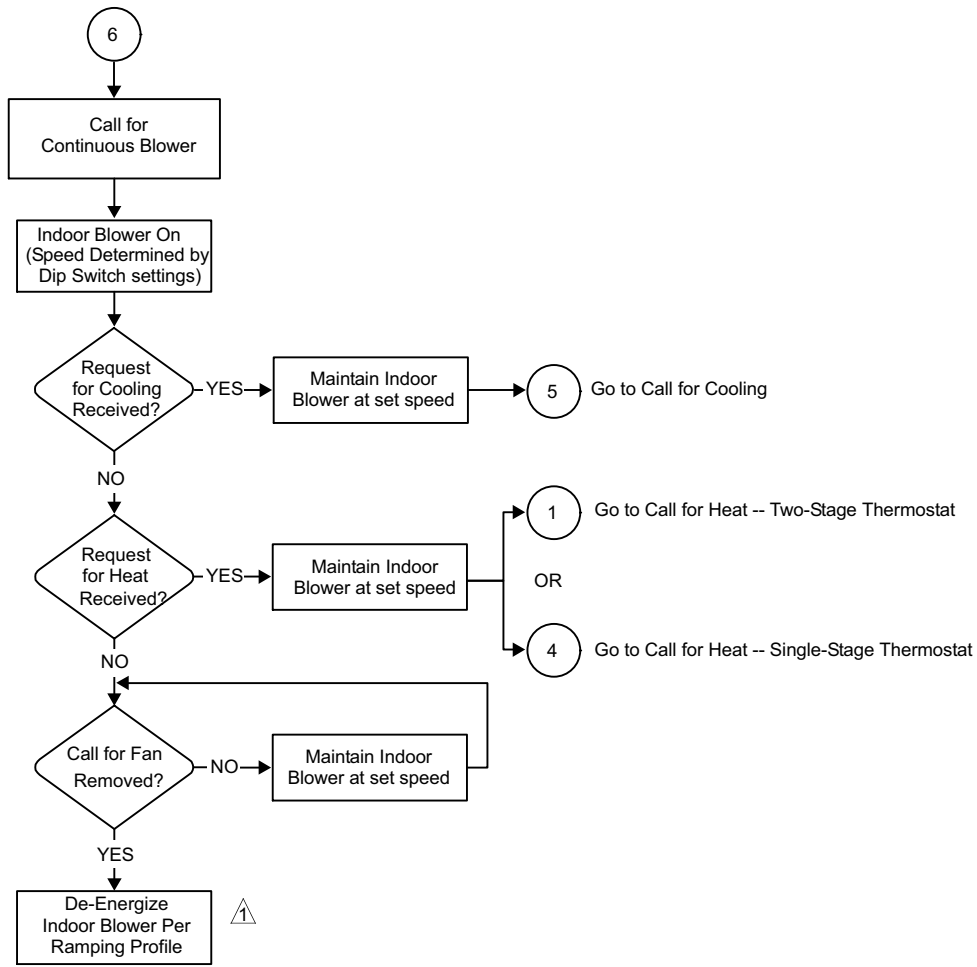


⚠ 1 2nd stage cooling operation requires a 2-stage thermostat, a 2-stage cooling system and on-board link W915 must be cut. The control will not respond to a 2nd stage cooling request unless a 1st stage cooling request is active

⚠ 2 Indoor blower cooling mode and high cooling mode have a specific ON, OFF and speed ramping profiles. The specific profile is selected using the DIP switches on the control.

# Troubleshooting: Continuous Fan Sequence of Operation

## CONTINUOUS LOW SPEED INDOOR BLOWER SEQUENCE OF OPERATION



⚠ Indoor blower low cooling mode and high cooling mode, have specific ON - OFF and speed ramping profiles. The specific profile is selected using the dip switches on the control.

## Repair Parts List

The following repair parts are available through Lennox dealers. When ordering parts, include the complete furnace model number listed on the CSA nameplate -- Example: G71MPP-36B-070-7. **All service must be performed by a licensed professional installer (or equivalent), service agency, or gas supplier.**

**Cabinet Parts**

- Upper access panel
- Blower access panel
- Top cap

**Control Panel Parts**

- Transformer
- Integrated control
- Door interlock switch
- Circuit breaker

**Blower Parts**

- Blower wheel
- Motor
- Motor mounting frame
- Power choke (1 hp only)
- Blower housing cut-off plate

**Heating Parts**

- Flame sensor
- Heat exchanger assembly
- Gas manifold
- Combustion air inducer
- Gas valve
- Main burner cluster
- Main burner orifices
- Pressure switches
- Ignitor
- Primary limit control
- Secondary limit control
- Flame rollout switches
- Combustion air inducer auxiliary limit
- H-fitting pressure switch assembly

## G71MPP Start-Up & Performance Check List

Job Name \_\_\_\_\_ Job No. \_\_\_\_\_ Date \_\_\_\_\_  
 Job Location \_\_\_\_\_ City \_\_\_\_\_ State \_\_\_\_\_  
 Installer \_\_\_\_\_ City \_\_\_\_\_ State \_\_\_\_\_  
 Unit Model No. \_\_\_\_\_ Technician \_\_\_\_\_  
 Serial No. \_\_\_\_\_

**Heating Section**

Electrical Connections Tight?

Supply Voltage \_\_\_\_\_ Blower Motor H.P. \_\_\_\_\_

Blower Motor Amps  Gas Piping Connections Tight & Leak-Tested?

Fuel Type: Natural Gas?  LP/Propane Gas?

Furnace Btu Input \_\_\_\_\_  
 Line Pressure \_\_\_\_\_

Regulator Pressure \_\_\_\_\_ w.c. - Nat.: \_\_\_\_\_ w.c. - LP/Propane

Flue Connections Tight?  Proper Draft?

Condensate Connections Tight?

Combustion Gas Tested?  CO<sub>2</sub>  CO

Fan Control Setting (45 Seconds Fixed On) \_\_\_\_\_

Fan Control Off Setting \_\_\_\_\_ Temperature Rise \_\_\_\_\_

Filter Clean & Secure?  Vent Clear?

**Thermostat**

Calibrated?  Heat Anticipator Properly Set?  Level?

## Requirements for Commonwealth of Massachusetts

### Modifications to NFPA-54, Chapter 10

#### Revise NFPA-54 section 10.8.3 to add the following requirements:

For all side wall, horizontally vented, gas-fueled equipment installed in every dwelling, building or structure used in whole or in part for residential purposes, including those owned or operated by the Commonwealth and where the side wall exhaust vent termination is less than seven (7) feet above the finished grade in the area of the venting, including but not limited to decks and porches, the following requirements shall be satisfied:

- 1 - **INSTALLATION OF CARBON MONOXIDE DETECTORS.** At the time of installation of the side wall, horizontally vented, gas-fueled equipment, the installing plumber or gasfitter shall observe that a hard-wired carbon monoxide detector with an alarm and battery backup is installed on the floor level where the gas equipment is to be installed. In addition, the installing plumber or gasfitter shall observe that a battery-operated or hard-wired carbon monoxide detector with an alarm is installed on each additional level of the dwelling, building or structure served by the side wall, horizontally vented, gas-fueled equipment. It shall be the responsibility of the property owner to secure the services of qualified licensed professionals for the installation of hard-wired carbon monoxide detectors.
  - a - In the event that the side wall, horizontally vented, gas-fueled equipment is installed in a crawl space or an attic, the hard-wired carbon monoxide detector with alarm and battery back-up may be installed on the next adjacent floor level.
  - b - In the event that the requirements of this subdivision cannot be met at the time of completion of installation, the owner shall have a period of thirty (30) days to comply with the above requirements; provided, however, that during said thirty (30) day period, a battery-operated carbon monoxide detector with an alarm shall be installed.
- 2 - **APPROVED CARBON MONOXIDE DETECTORS.** Each carbon monoxide detector as required in accordance with the above provisions shall comply with NFPA 720 and be ANSI/UL 2034 listed and IAS certified.
- 3 - **SIGNAGE.** A metal or plastic identification plate shall be permanently mounted to the exterior of the building at a minimum height of eight (8) feet above grade directly in line with the exhaust vent terminal for the horizontally vented, gas-fueled heating appliance or equipment. The sign shall read, in print size no less than one-half (1/2) inch in size, "GAS VENT DIRECTLY BELOW. KEEP CLEAR OF ALL OBSTRUCTIONS."

- 4 - **INSPECTION.** The state or local gas inspector of the side wall, horizontally vented, gas-fueled equipment shall not approve the installation unless, upon inspection, the inspector observes carbon monoxide detectors and signage installed in accordance with the provisions of 248 CMR 5.08(2)(a) 1 through 4.

#### **EXEMPTIONS: The following equipment is exempt from 24 CMR 5.08(2)(a) 1 through 4:**

- 1 - The equipment listed in Chapter 10 entitled "Equipment Not Required to Be Vented" in the most current edition of NFPA 54 as adopted by the Board; and
- 2 - Product Approved side wall, horizontally vented, gas-fueled equipment installed in a room or structure separate from the dwelling, building or structure used in whole or in part for residential purposes.

#### **MANUFACTURER REQUIREMENTS - GAS EQUIPMENT VENTING SYSTEM PROVIDED.**

When the manufacturer of Product Approved side wall, horizontally vented, gas-fueled equipment provides a venting system design or venting system components with the equipment, the instructions provided by the manufacturer for installation of the equipment and the venting system shall include:

- 1 - Detailed instructions for the installation of the venting system design or the venting system components: and
- 2 - A complete parts list for the venting system design or venting system.

#### **MANUFACTURER REQUIREMENTS - GAS EQUIPMENT VENTING SYSTEM NOT PROVIDED.**

When the manufacturer of Product Approved side wall, horizontally vented, gas-fueled equipment does not provide the parts for venting the flue gases, but identifies "special venting systems," the following requirements shall be satisfied by the manufacturer:

- 1 - The referenced "special venting system" instructions shall be included with the appliance or equipment installation instructions; and
- 2 - The "special venting systems" shall be Product Approved by the Board, and the instructions for that system shall include a parts list and detailed installation instructions.

**A copy of all installation instructions for all Product Approved side wall, horizontally vented, gas-fueled equipment, all venting instructions, all parts lists for venting instructions, and/or all venting design instructions shall remain with the appliance or equipment at the completion of the installation.**